

Course: 3D Design
Title: Mesh Modeling – Vase and Flower
Dropbox File: VaseAndFlower.zip
Blender: Version 2.41
Level: Beginning
Author: Neal Hirsig (nhirsig@tufts.edu)

Mesh Modeling – Vase and Flower

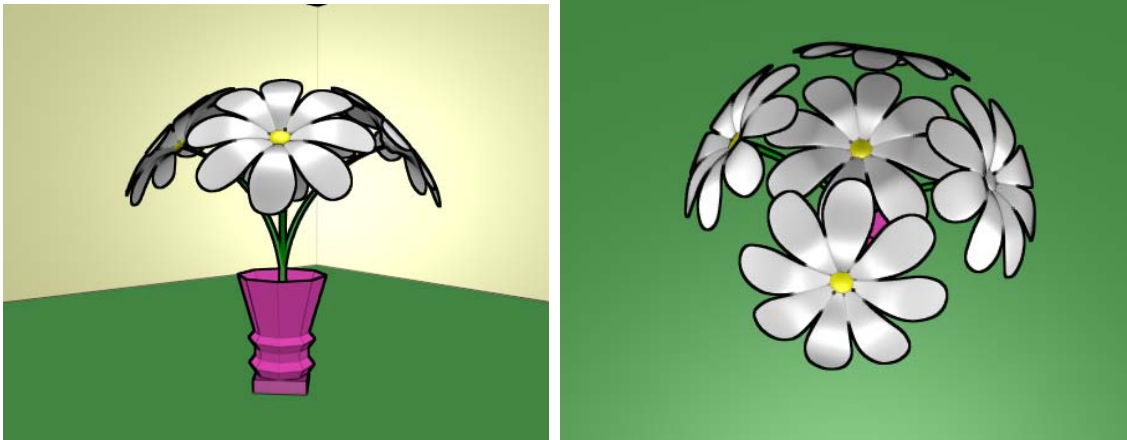

In this tutorial, we'll create a vase and flower model and render it using Blender's "Toon" shaders.

Open MyBlender.blend (or the default if you are using MyBlender as the default Blender file).

We will use the Default Cube Object for this tutorial. Select the Default cube in Object Mode. In the Transform Properties Panel on the right change the Size X: to 2, Size Y to 2 and Size Z to .5

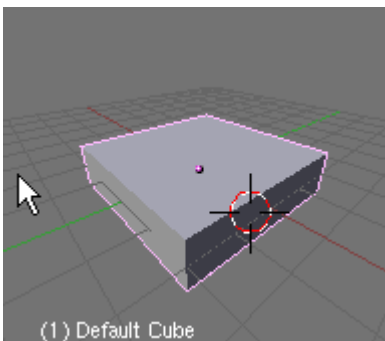
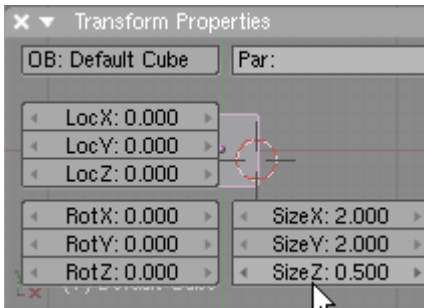

Press the AKEY to deselect the cube. While in Top View place your 3D cursor in the center of the cube. Press Space / Add / Mesh / Circle. Set the Vertices to 8.

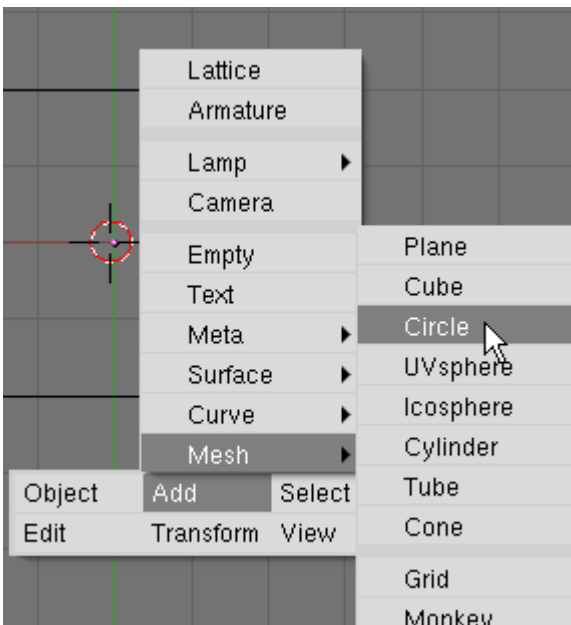

Press the SKEY and scale the circle to the size of the cube.

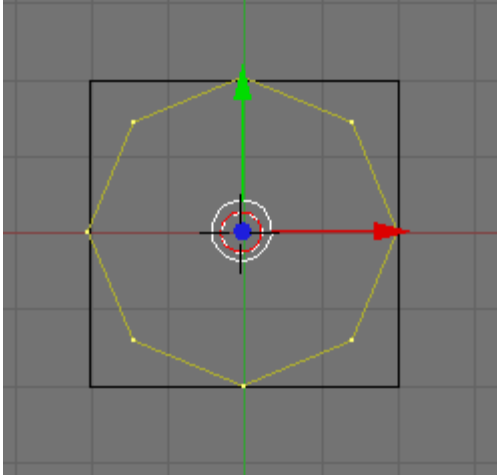

Switch to front view (NUM1). Use the Blue Transform Widget Arrow to move the vertices up to the top of the cube as shown.

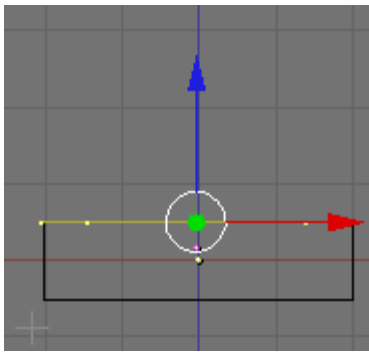

Press the EKEY (Extrude) Select “Only Edges”; then press the ZKEY (to constraint the extrusion to the z axis). Extrude the edges up a bit as shown below.

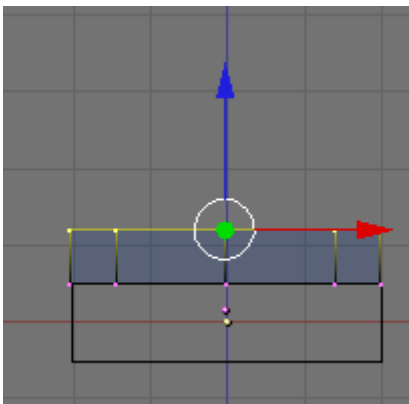

Press the ZKEY. Rotate your view in the main 3D viewport to gain a view like the one shown below.

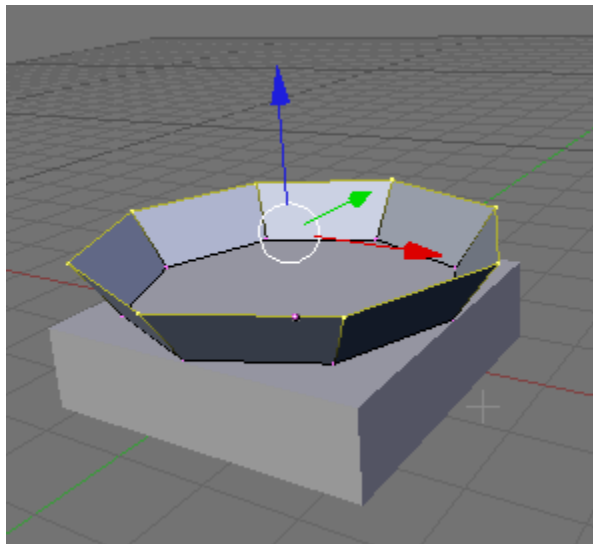
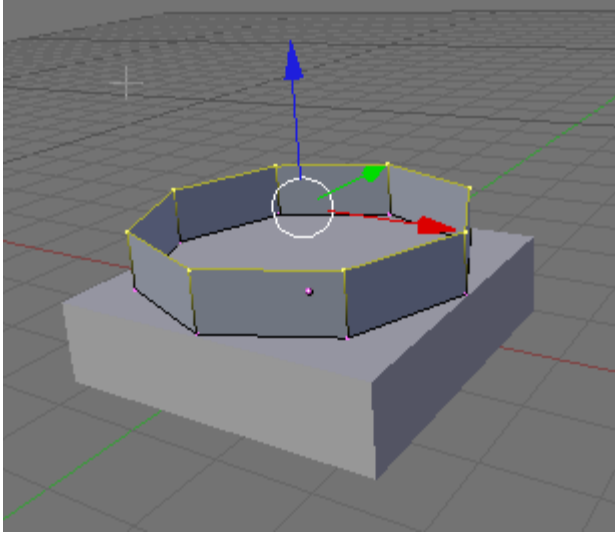

Scale out a bit.

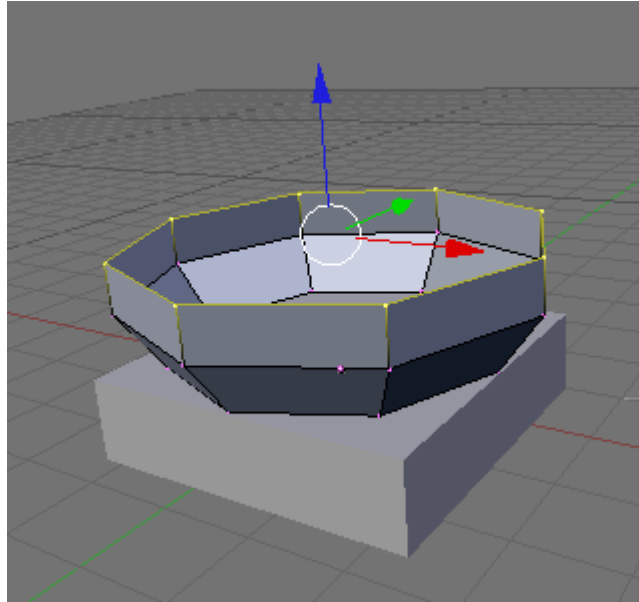

Extrude Edges (Z axis)

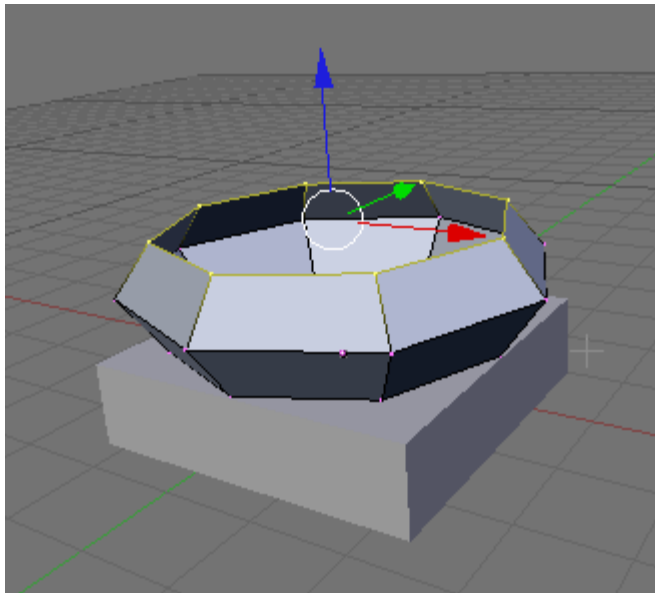

Scale in a bit.

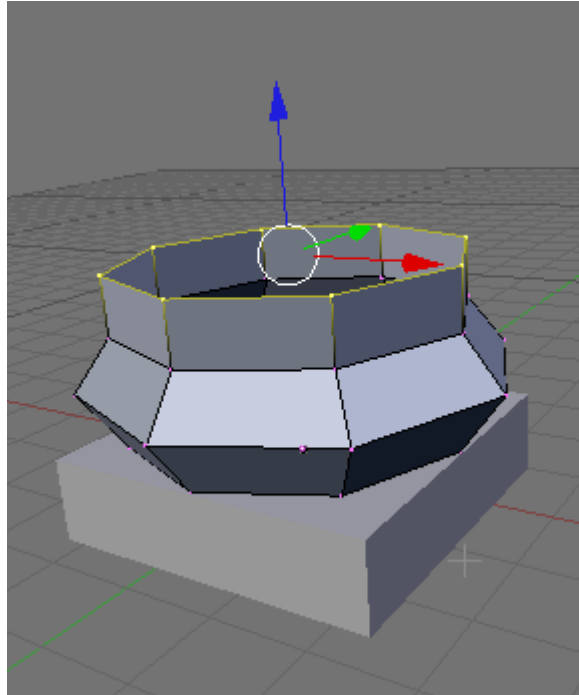

Extrude Edges (Z axis)

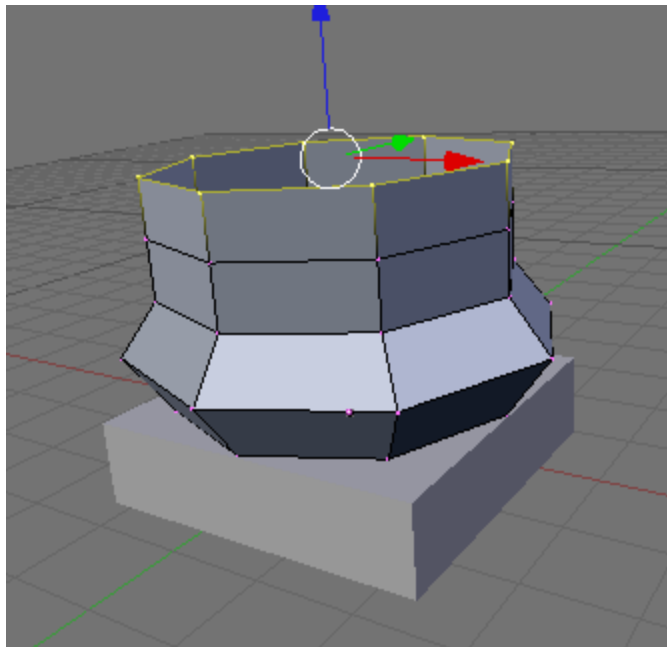

Again Extrude Edges (Z axis)

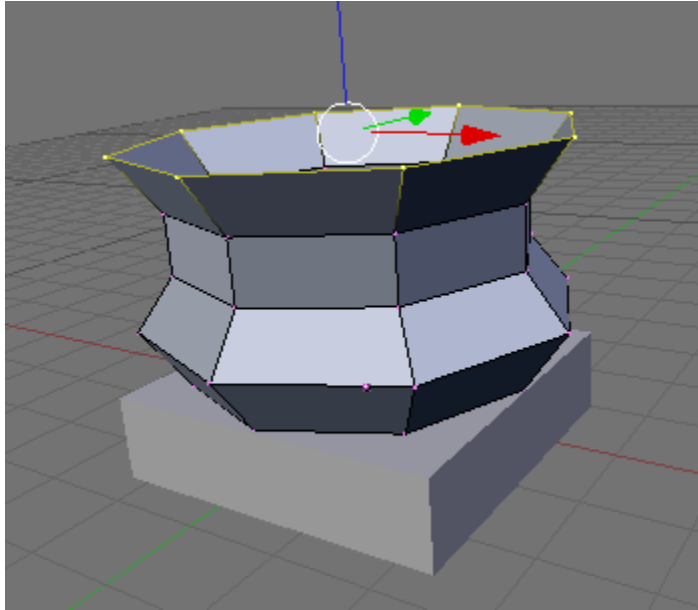

Scale out a bit.

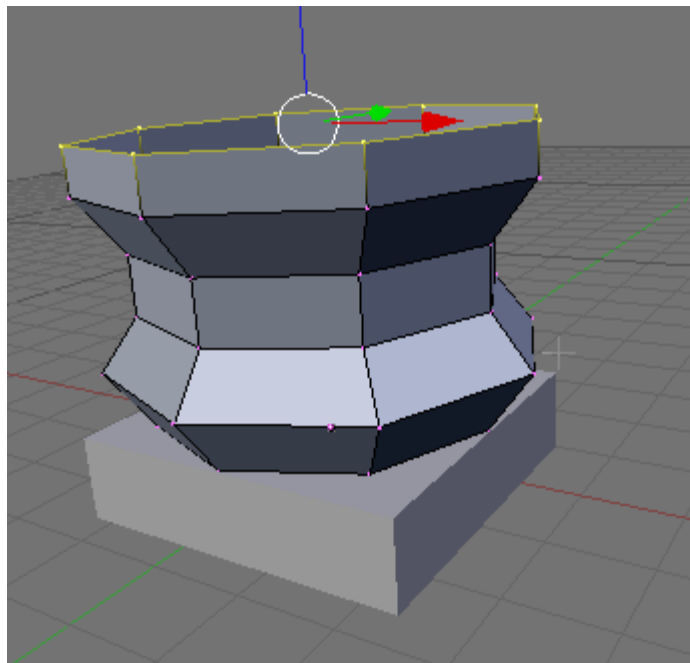

Extrude Edges (Z axis)

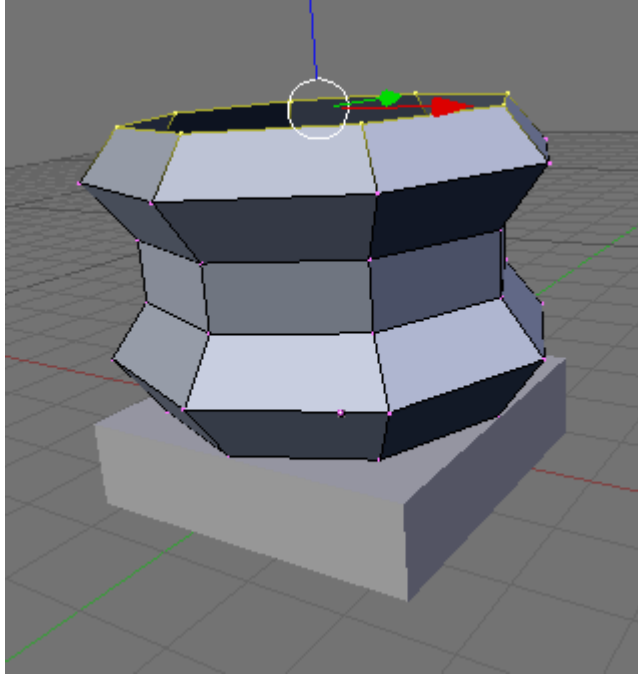

Scale in a bit.

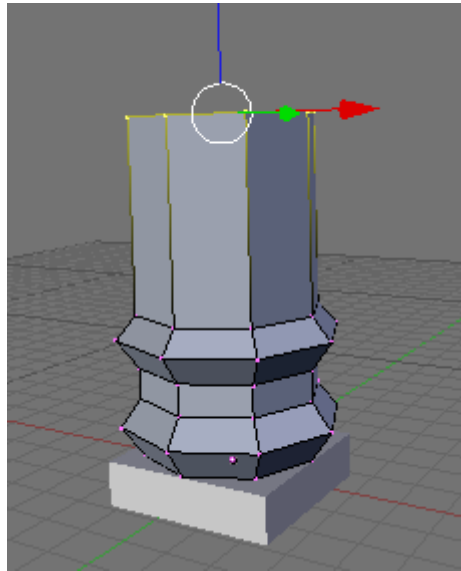

Extrude Edges (Z axis)

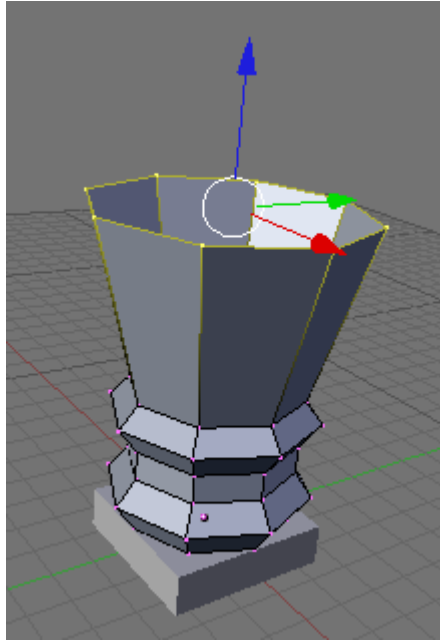

Scale out a bit.

TAB to Object Mode. Select both the cube and circle objects. Press CTRL-J and join them together into one object.

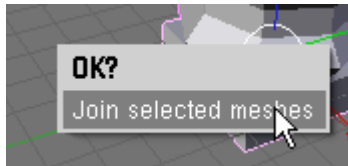

In the Transform Properties Panel name this object Vase.

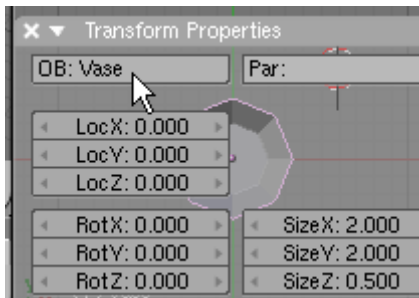

Press F9 (Editing) if not already displayed. With the Vase selected press the Centre New button in the Mesh Panel. (This repositions the objects center to the real center of the whole vase).

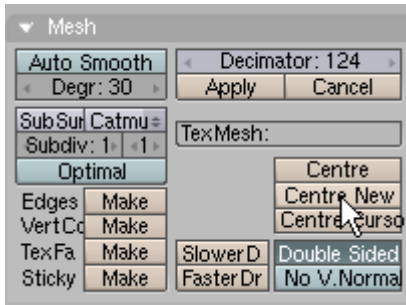

Save your file F2. (Call it VaseAndFlower.blend).

Press the ZKEY (return to wireframe mode). Switch to Top view (You may have to press NUM5 to get a true orthographic top view)

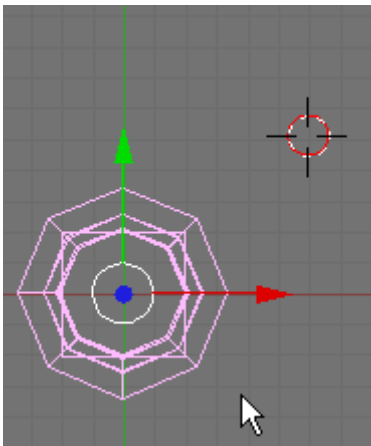

With the vase selected press the MKEY (layer) and place the vase on layer 2. (Leave layer 2 inactive.)



In layer 1, top view, place your 3D cursor in the center of the display and press Space / Add / Mesh / Circle. Choose 16 vertices.

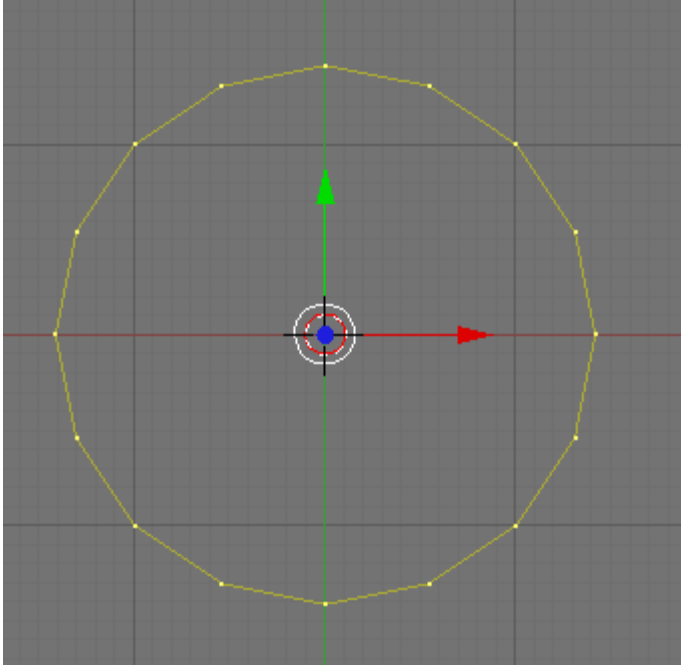

Using the GKEY, Grab and rearrange the vertices to form a sort of petal shape as shown below.

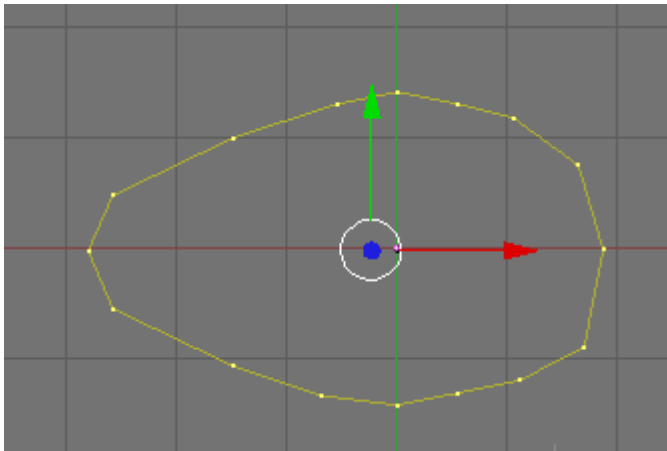

With all of the vertices selected (AKEY); in the Mesh Tools Panel press the Subdivide button once.

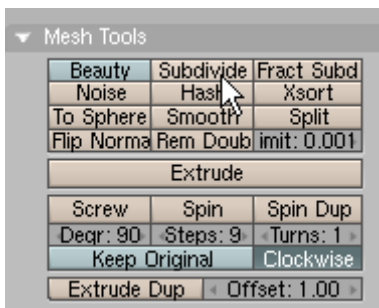

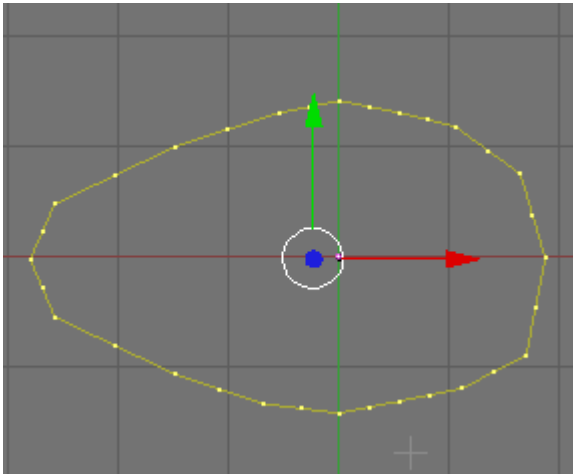

With all the vertices still selected; in the Mesh Tools Panel **press the Smooth button 4 times.**

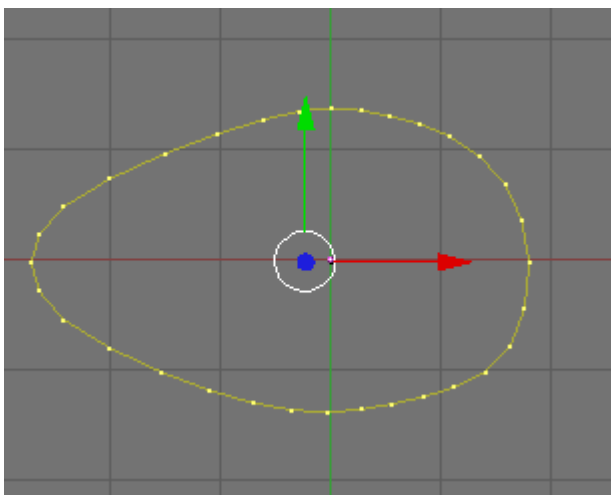
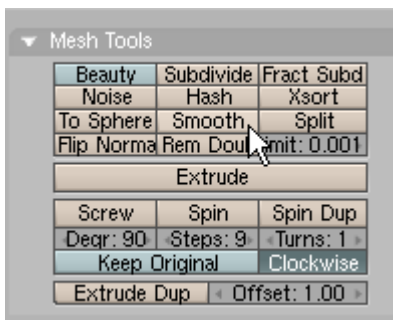

Select the vertex on the far right of the petal shape **ONLY**.

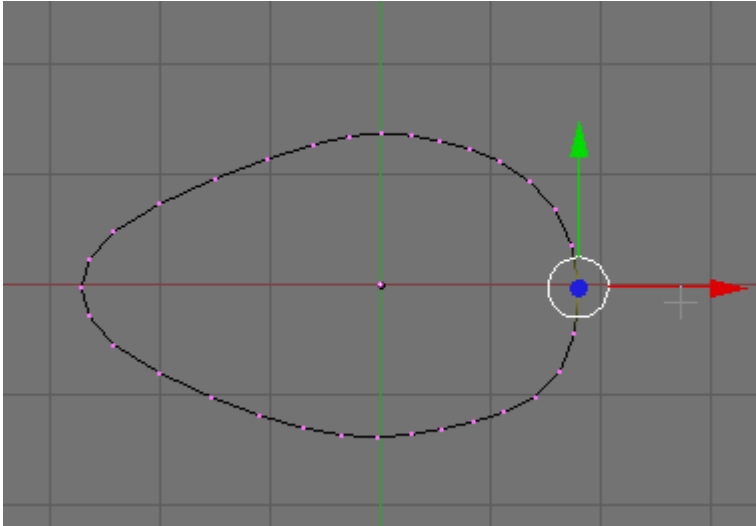

Switch to Front View NUM1

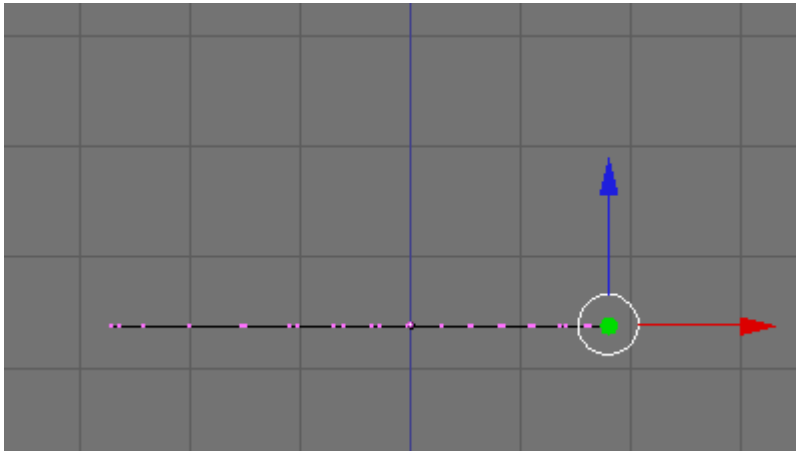

Press the Proportional Editing button and turn it on.

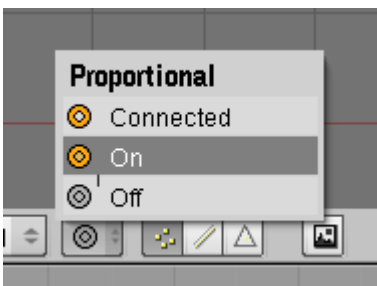

In the Falloff button next to it choose Sphere Falloff.



Zoom out a bit and press the GKEY (Grab). You will see a circle which shows the extent of the proportional falloff.

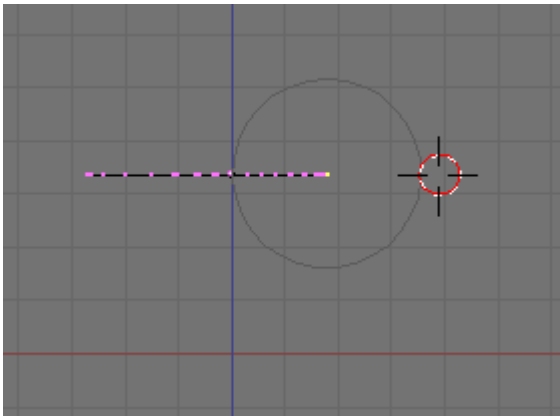

Use your mouse track wheel to make the circle large enough to encompass the entire object.

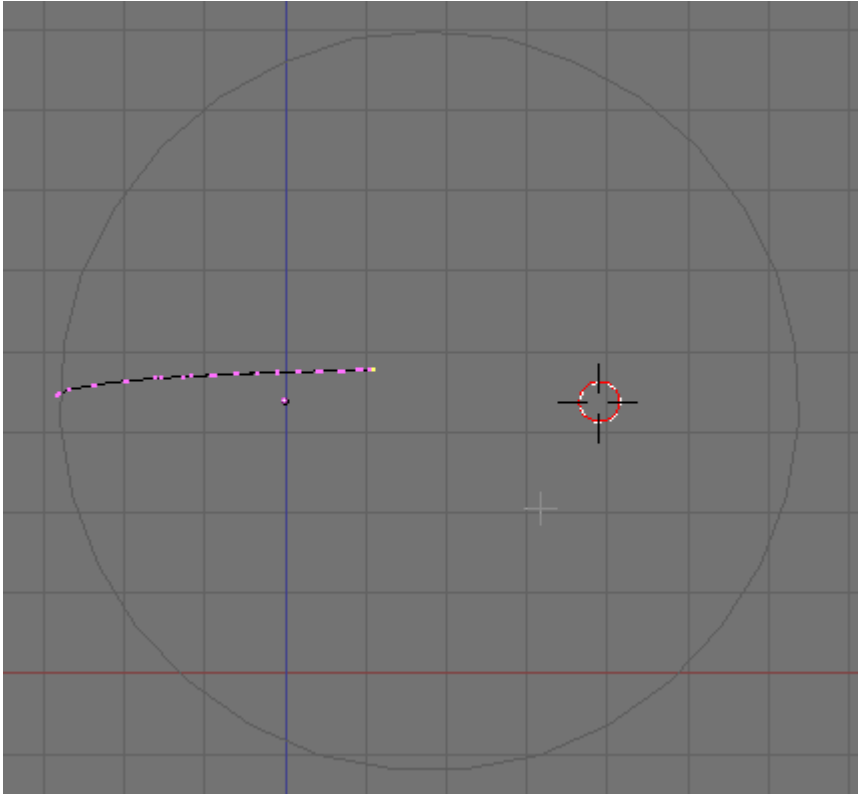

Then raise the vertex up and shape it as seen below (the other vertices will follow the selected vertex and bend the object in a curve).

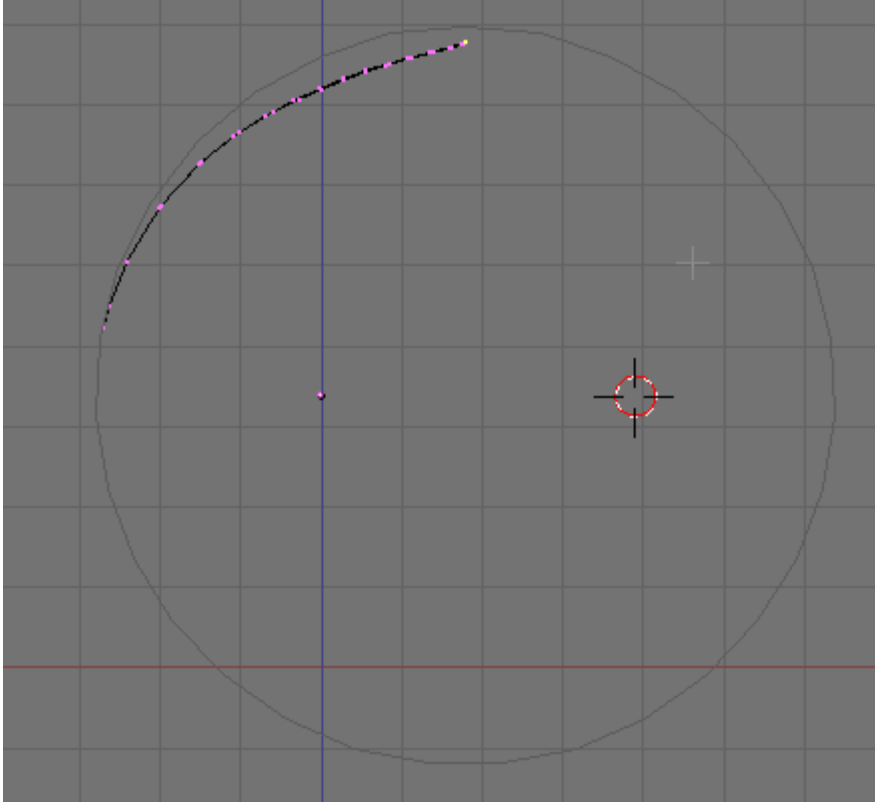

The object is now curved (in front view).

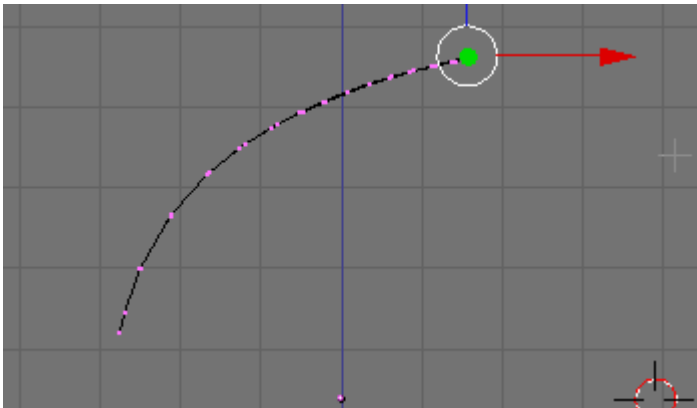

Turn off Proportional Editing.

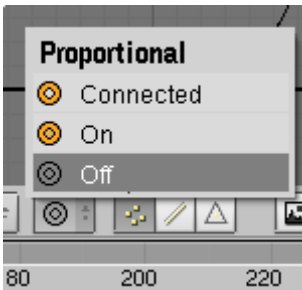

Switch to top view (NUM7). We will now add faces to the object forming a petal shape. Select the 3 left vertices as shown.

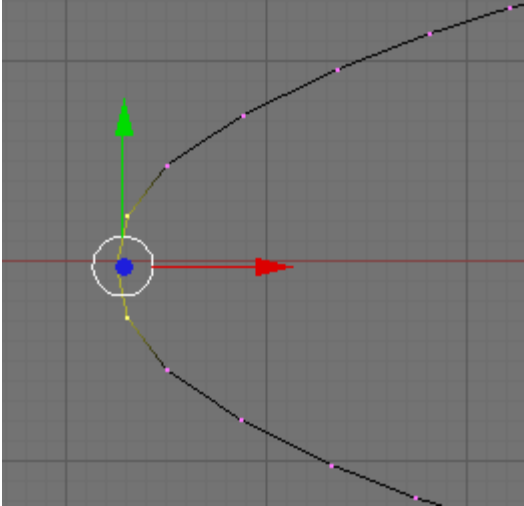

Press the FKEY (Face). This creates a face based on the 3 vertices.

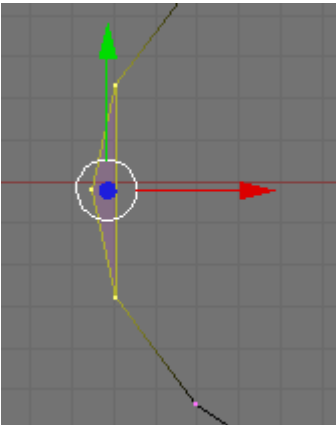

Press the AKEY to deselect the vertices. Select the 3 rightmost vertices as shown.

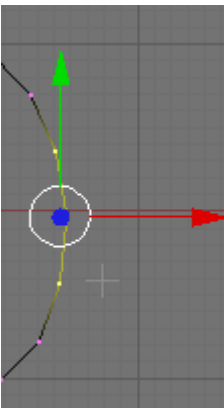

Press the FKEY (Face). This creates a face on the right based on the 3 selected vertices. You will be able to see it easier by pressing the ZKEY and view the petal in shaded mode.

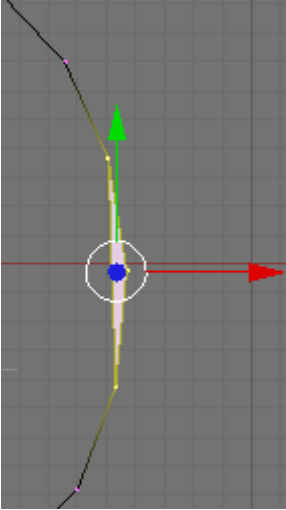

Press the AKEY to deselect the vertices. Go back to the left side of the petal. Press the BKEY (Box Select) and box select the 2 rightmost vertices of the existing face and the next 2 vertices as shown.

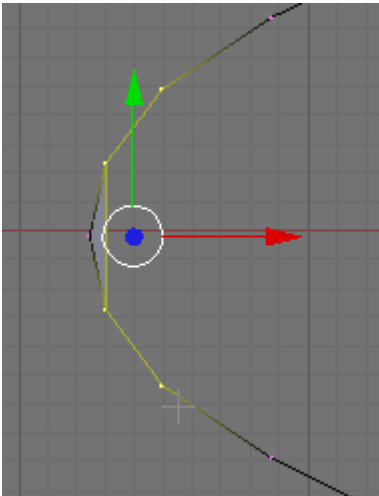

Press the FKEY (Face). A new face will be drawn based on the 4 vertices selected.

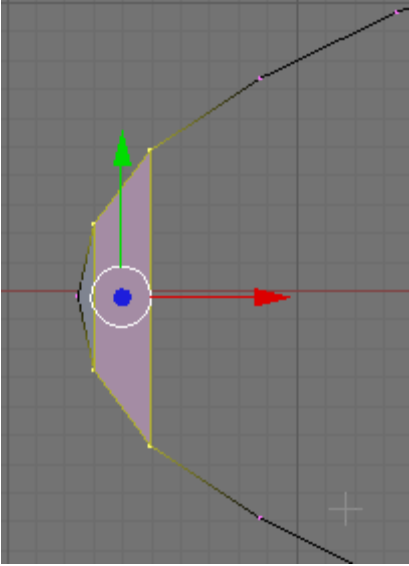

Press the **AKEY** to deselect the vertices. Press the **BKEY** and box select the 2 rightmost vertices of the last face and the 2 next vertices as shown.

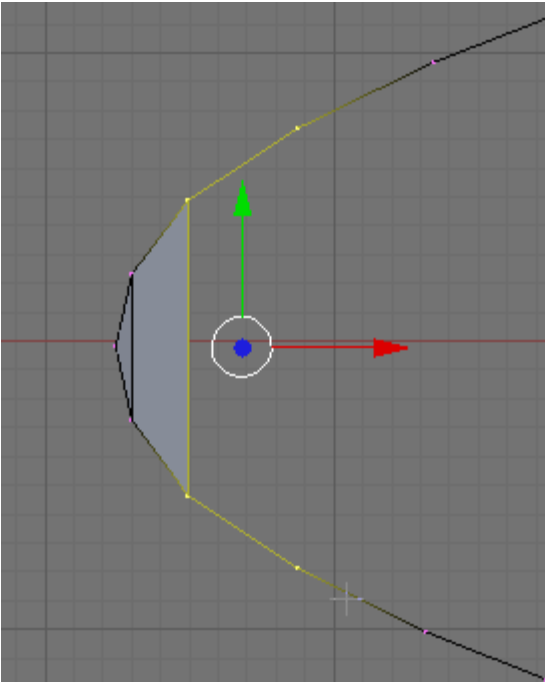

Press the **FKEY** (Face). This will create a new face.

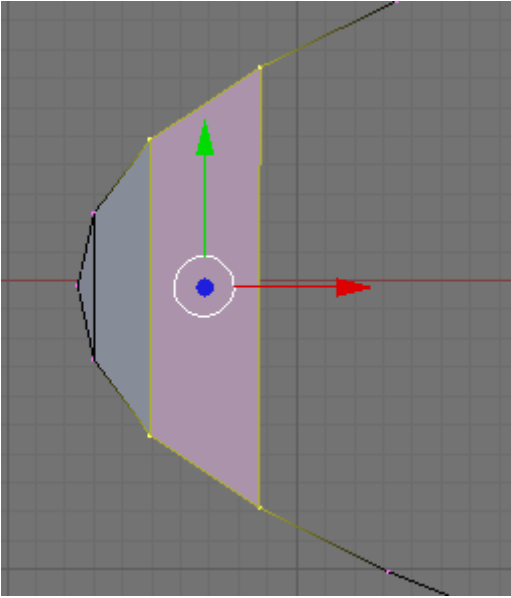

Continue on in this fashion until you have created faces for the entire petal.

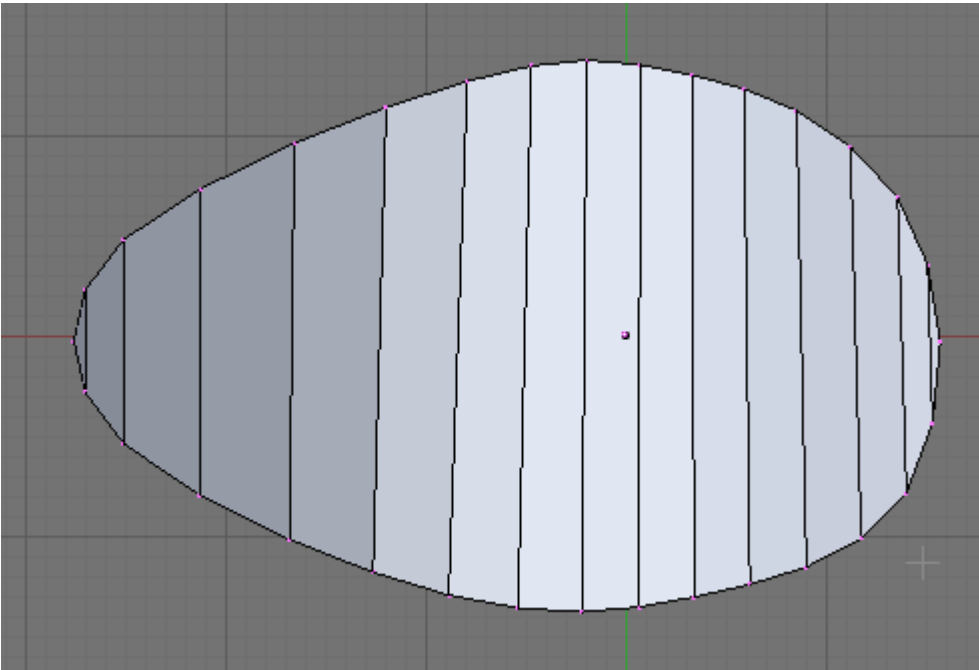

Switch to Front View. Press the AKEY to select all of the vertices. Press the EKEY (Extrude) and choose Region.

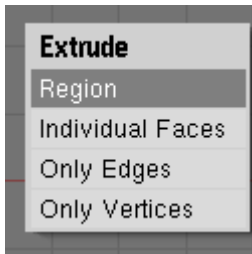

Extrude the petal VERY LITTLE as shown.

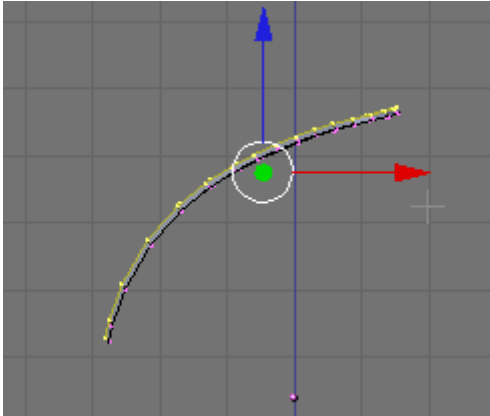

Press the **A**KEY to deselect the vertices. **TAB** to exit **Edit Mode**. Rotate your view to see the Petal.

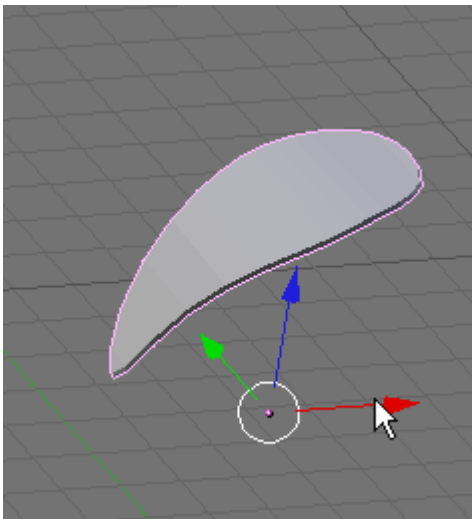

Switch to top view and place your 3D cursor to the left of the petal. Press **Space / Add / MESH / UV Sphere**. Use 18 segments and 18 rings.

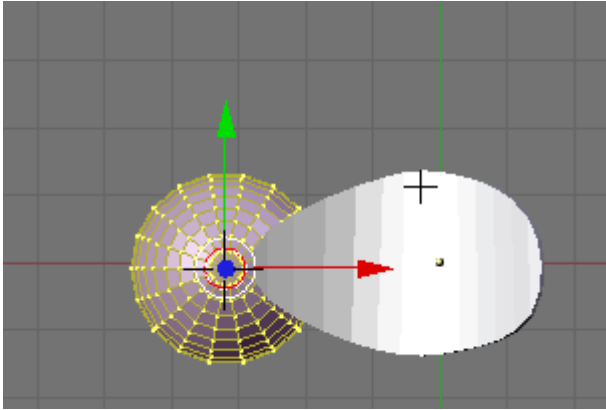

Switch to Front View. Press the SKEY (Scale) then the ZKEY to constrain it to the Z axis and scale it down (squashing it) as shown.

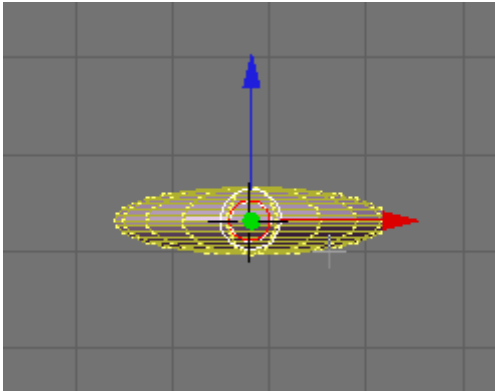

TAB to Exit Edit Mode. Use the Blue Transform Widget arrow to move the sphere up to the position of the petal.

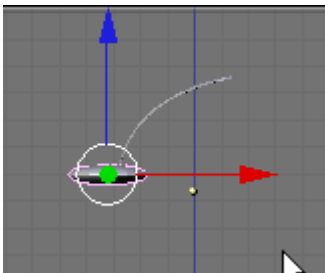

Switch to top view. With the sphere selected, press the SKEY and scale it down a bit as shown.

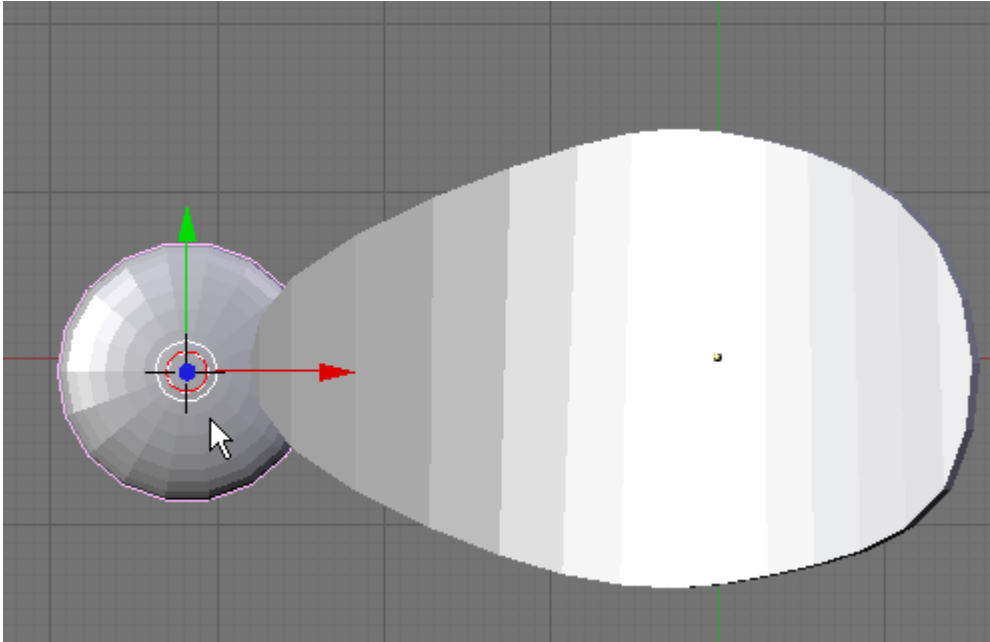

Switch to front view. Select the petal object and Press the RKEY (Rotate) and rotate it a bit as shown.

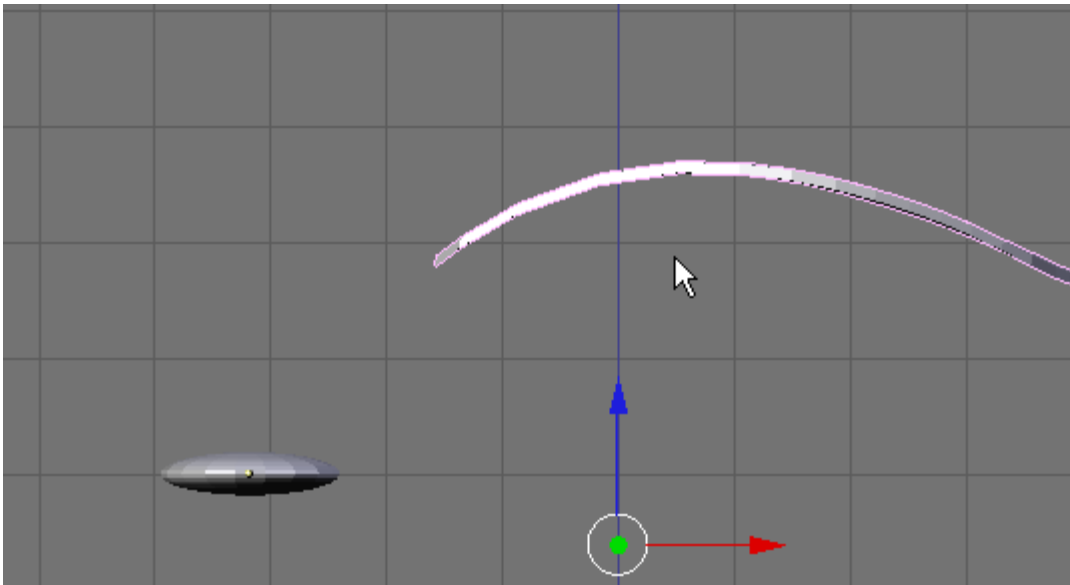

Press the GKEY (Grab) and move the petal just into the sphere.

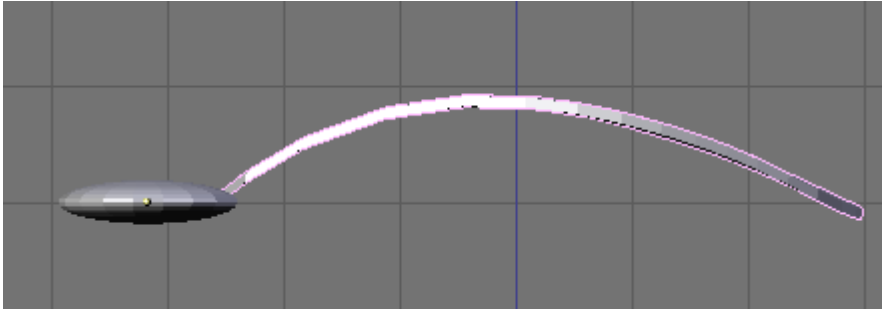

Rotate your viewport and move the petal so that it looks as if it is attached to the sphere as shown

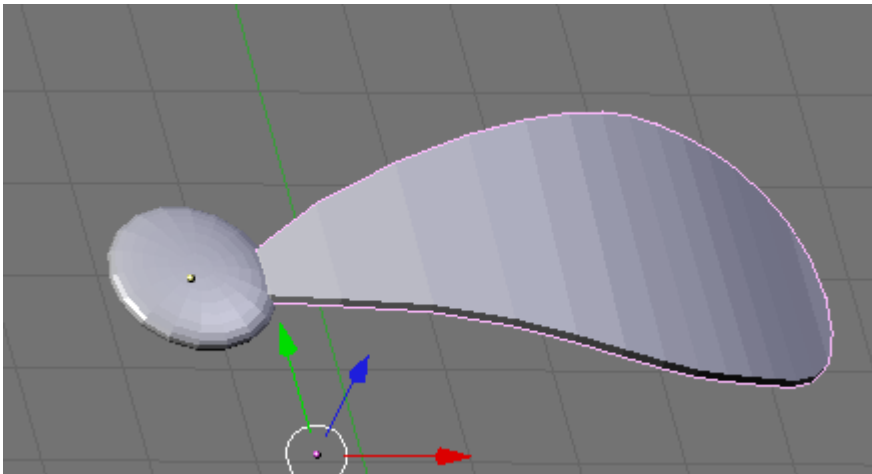

Switch to top view. Place your 3D cursor in the center of the sphere. Press the Rotation/Scaling Pivot button and set the Pivot point to 3D Cursor.

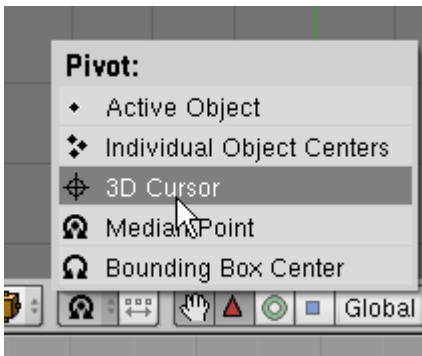

With the petal selected, press SHIFT-D (Duplicate). Then press the RKEY (Rotate) and rotate the new petal directly opposite of the original as shown.

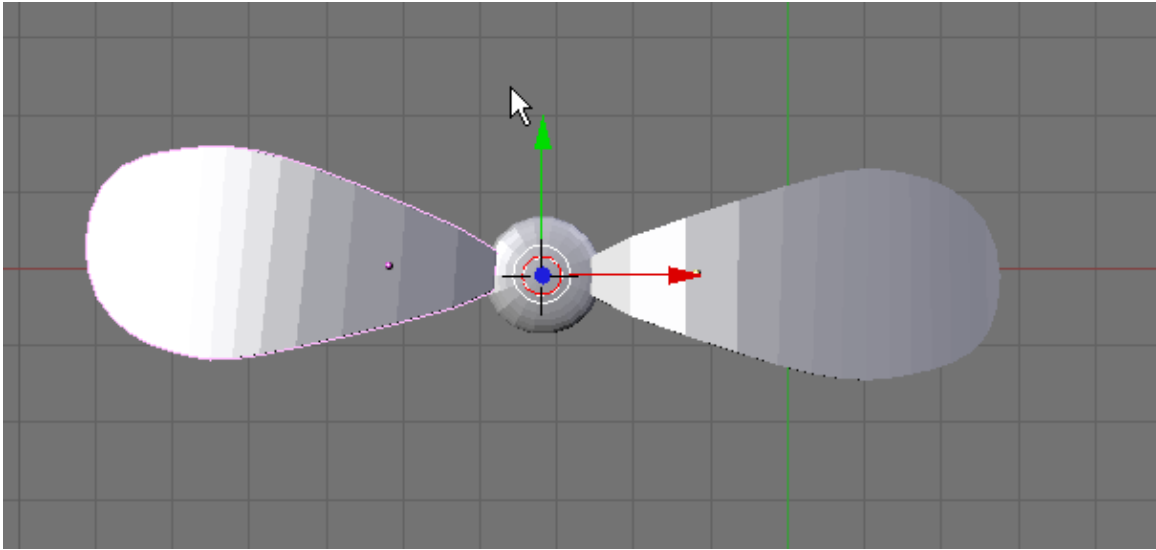

With the new petal selected Press SHIFT-D (Duplicate). Then Press the RKEY and rotate the new petal as shown.

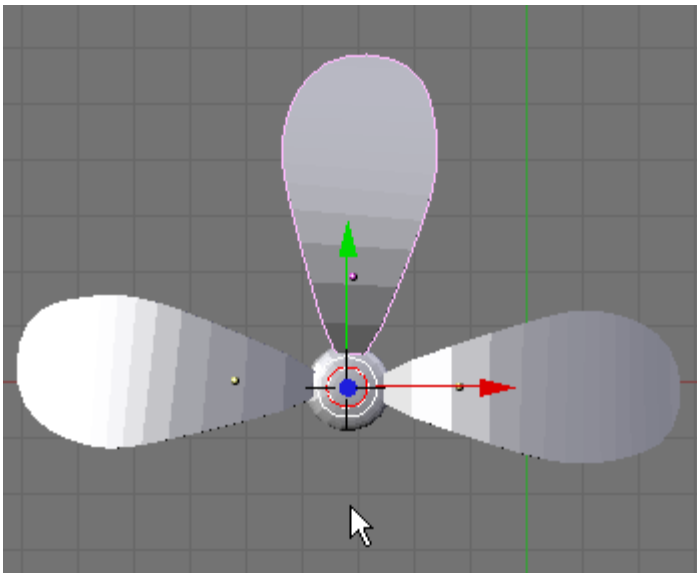

Continue in this fashion until you have a total of 8 petals as shown below.

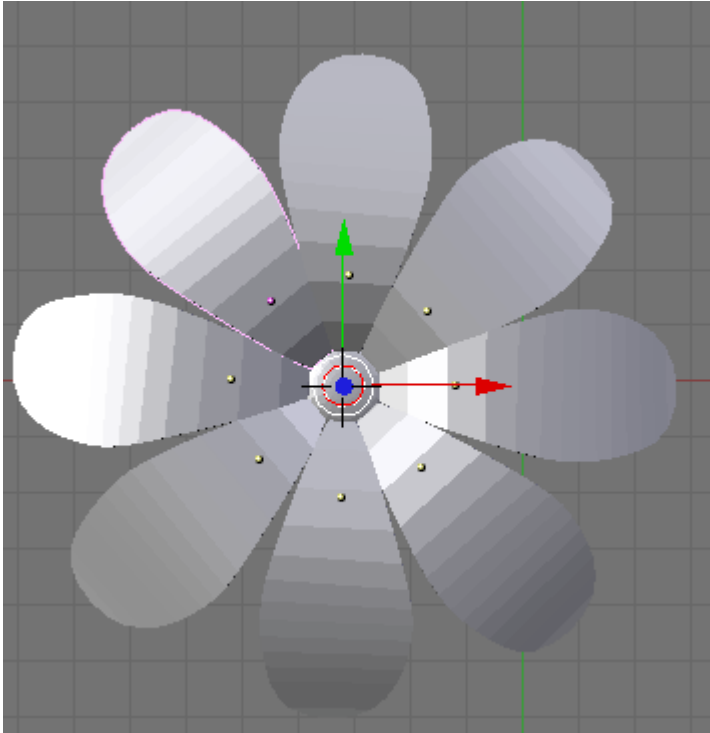

Press the AKEY to deselect any petals. Hold the SHIFT KEY down and RMB select the eight petals (make sure the center sphere is NOT selected). Press CTRL-J (Join). And select Join selected Meshes

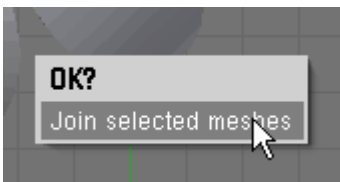

The petals are now one object. In the Transform Properties Panel name this object Petals.

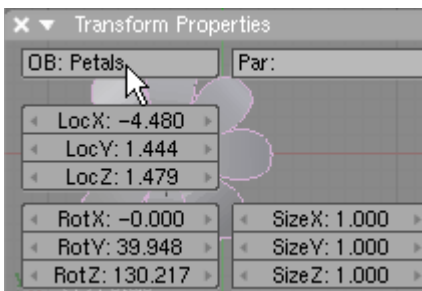

With the Petals object selected; In the Mesh Panel press the Center New button (to fix the petals center to the center of the object) and in the Link and Materials Panel press the Set Smooth button.

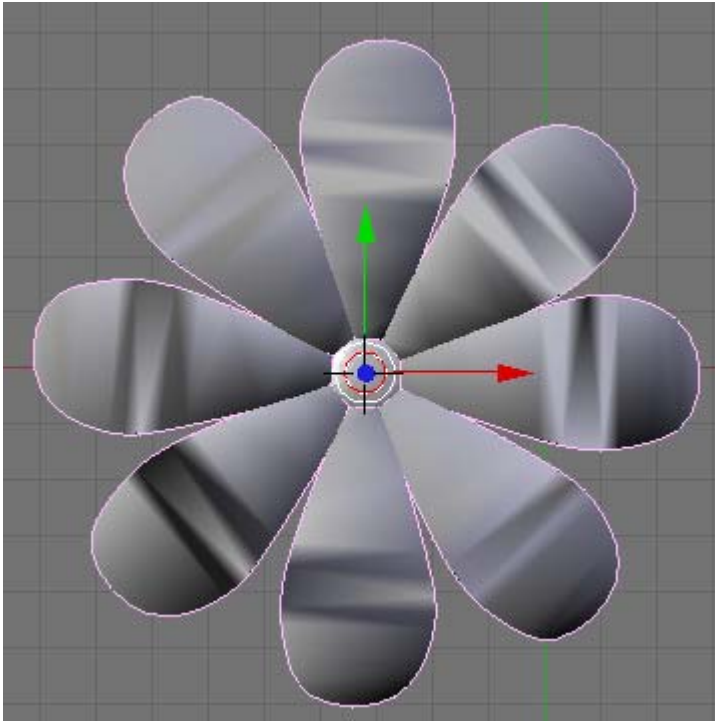
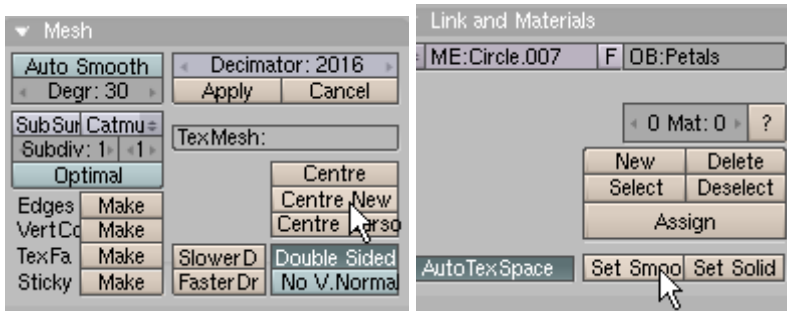

In the Modifier Panel press the Add New button. Select the SubSurf modifier from the list.

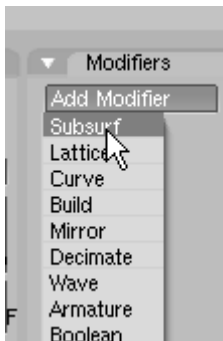

In the SubSurf controls set the Levels to 2 and the Render Levels to 2

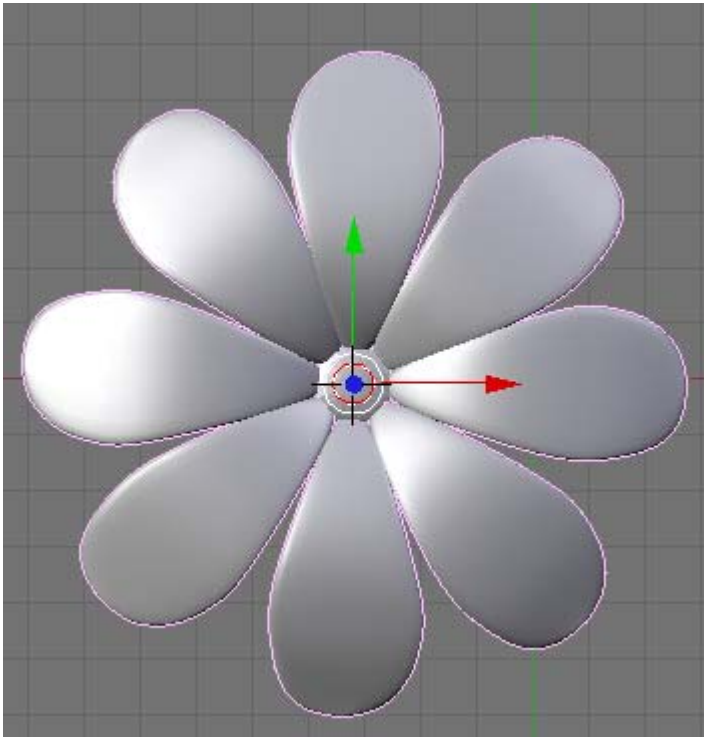
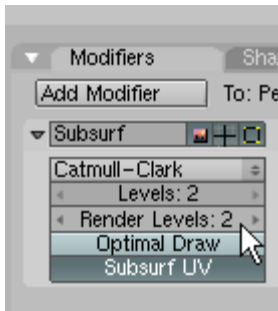

Press the AKEY to deselect the Petals object. Select the center sphere. In the Transform Properties Panel name this object Button.

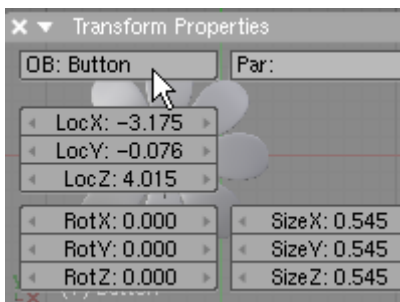

In the Mesh Panel press the Center New button and In the Links and Materials Panel press the Set Smooth button.

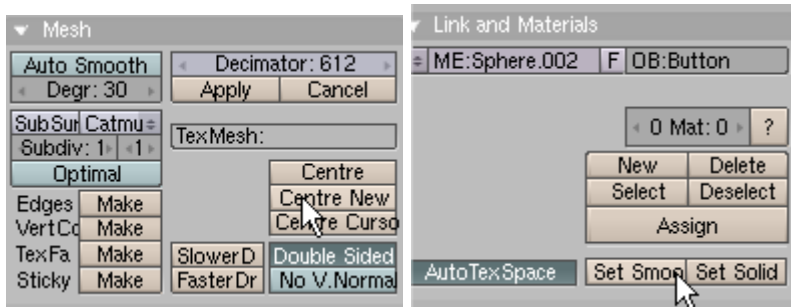

Set the Rotation/Scaling Pivot Point back to Median Point.

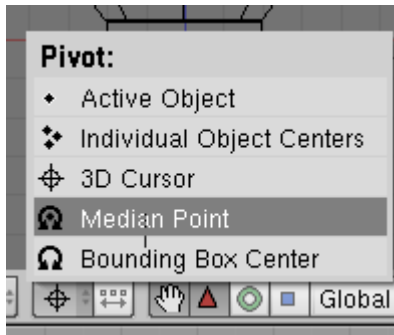

With both the Button and Petals objects selected, press the MKEY (Layer) and place the Petals and Button objects on layer 3.



Activate Layer 2 (the vase) only. Press the AKEY to deselect the Vase object. Press the ZKEY to enter wireframe view. Place your 3D cursor in the center of the vase. Press Space / Add / Mesh / Cylinder. Choose 12 Vertices. Scale the cylinder down to very small as shown.

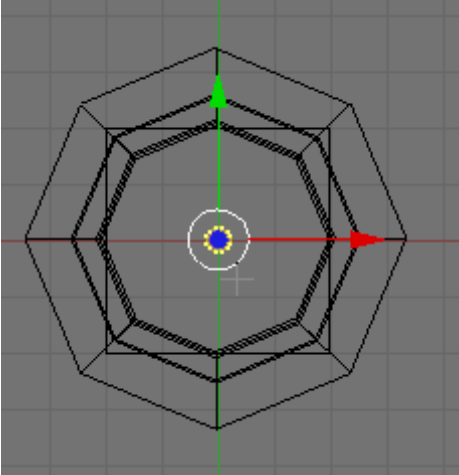

Switch to front view. Use the Blue Transform Widget Arrow to move the cylinder up so it is resting at the bottom of the vase.

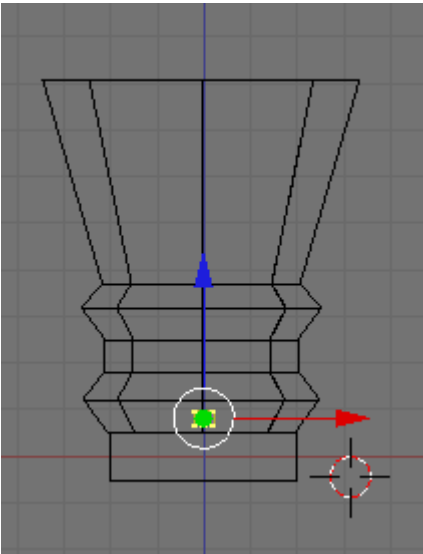

Press the AKEY to deselect the vertices. Zoom in and box select (BKEY) the topmost vertices.

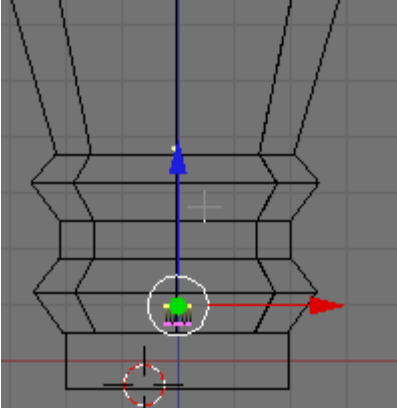

Zoom out a bit and use the Blue Transform Widget to move these vertices up to form a flower stem as shown.

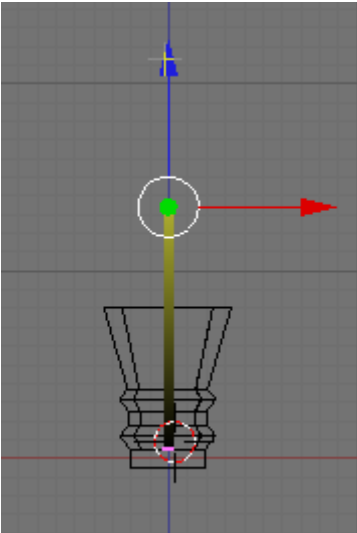

Press the AKEY to deselect the vertices. **TAB out of Edit Mode.** In the Properties Panel name this object Straight Stem. In the Mesh Panel Press the Center New button (re-centering its center point).

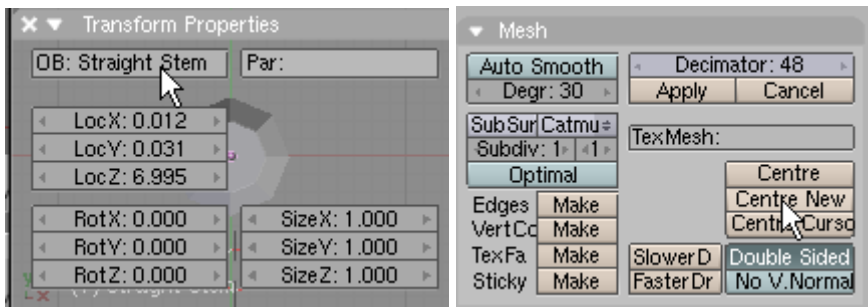

With the Straight Stem object selected, Press SHIFT-D (Duplicate). Move the duplicate stem out of the vase and to the side.

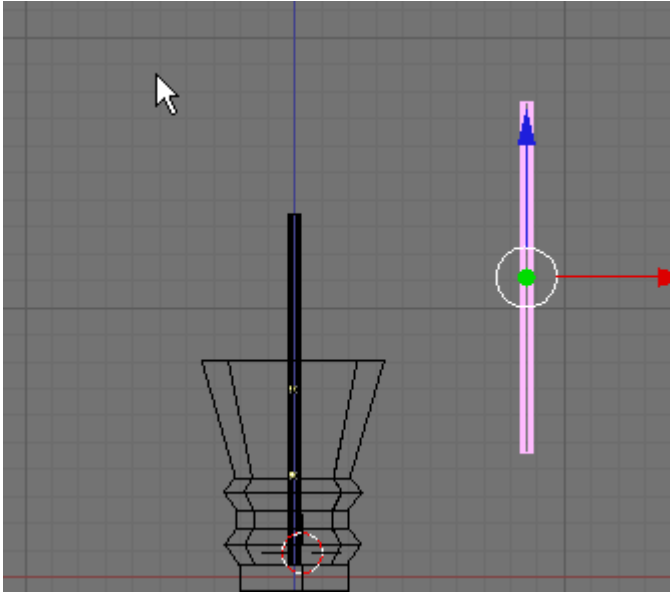

TAB to Edit Mode. Press the AKEY to select all of the vertices of the duplicate stem.

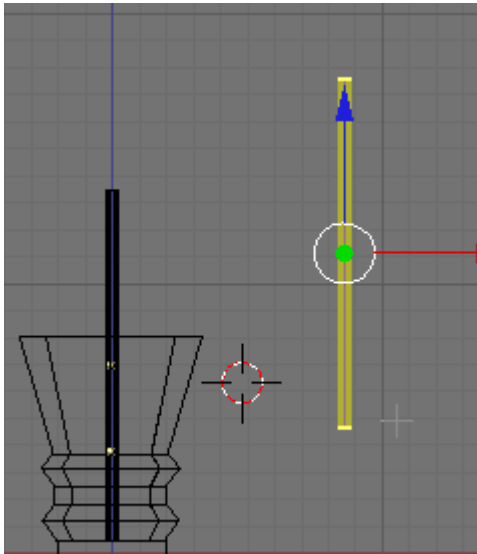

In the Mesh Tools Panel press the Subdivide Button **4 times**.

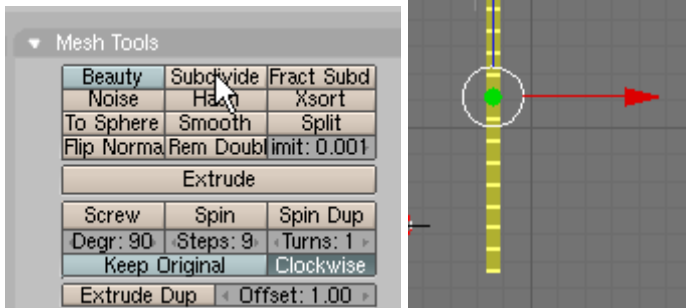

Turn on Proportional Editing. And set the falloff to Sphere.

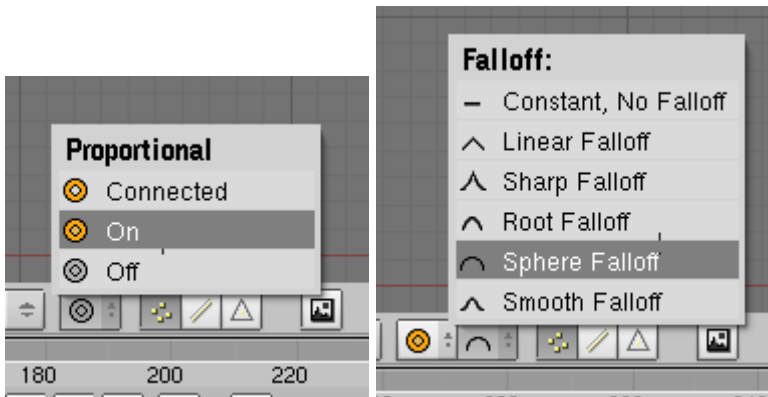

Press the AKEY to deselect the vertices. Box Select (BKEY) the bottom vertices only.

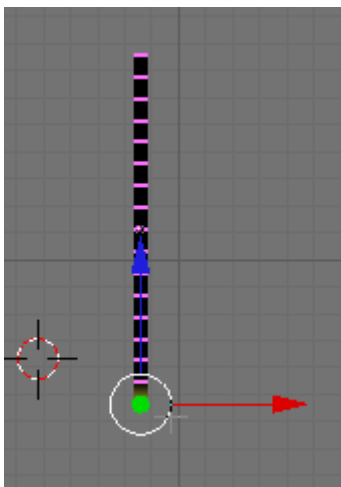

Press the GKEY (Grab) and adjust your track wheel so that the falloff circle encompasses the entire stem.

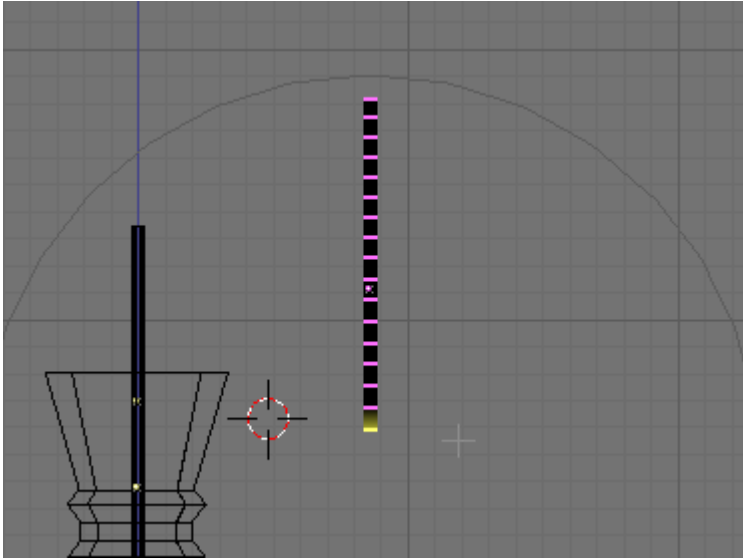

Move the vertices to the left and up so that the stem forms a bend as shown. (LMB click to release).

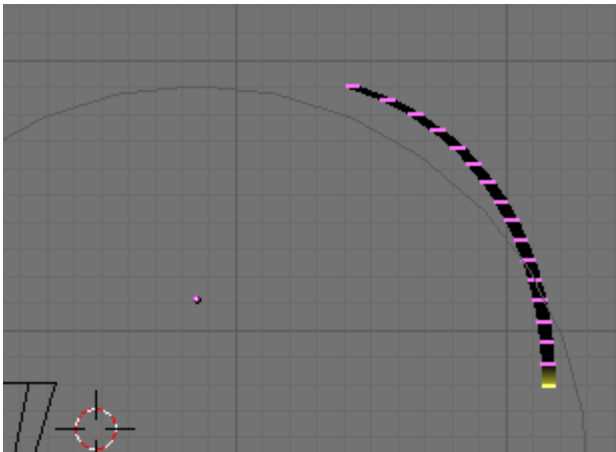

Press the AKEY to deselect the vertices. **Turn off Proportional Editing.**

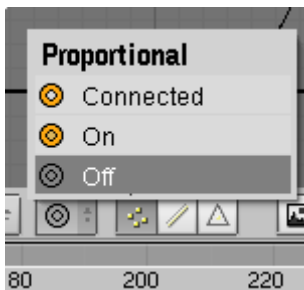

TAB out of Edit Mode. In the Transform Properties Panel name this object Curved Stem. In the Mesh Panel press the Center New button.

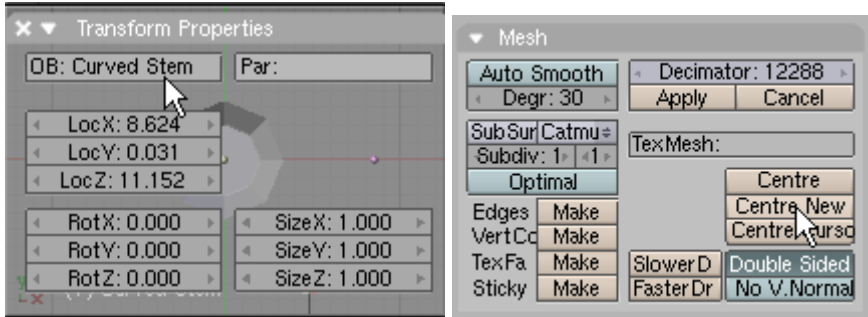

SHIFT LMB select the layer 3 button adding it to the scene.

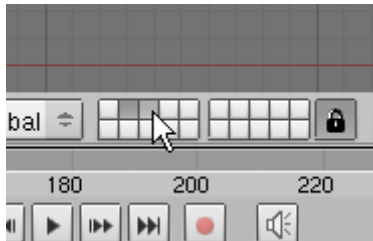

Switch to Top View. Select the Button and the Petals objects. Switch to Front View. Press the GKEY (Grab) and move the Button and Petal objects to the top of the Straight Stem object.

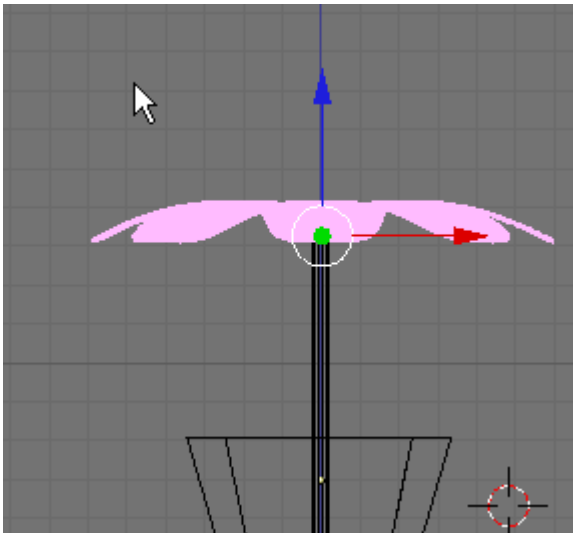

Press the ZKEY (shaded Mode) and rotate your front view to ensure that the Straight Stem is not sticking out of the Button. Adjust the Button and Petals if needed.

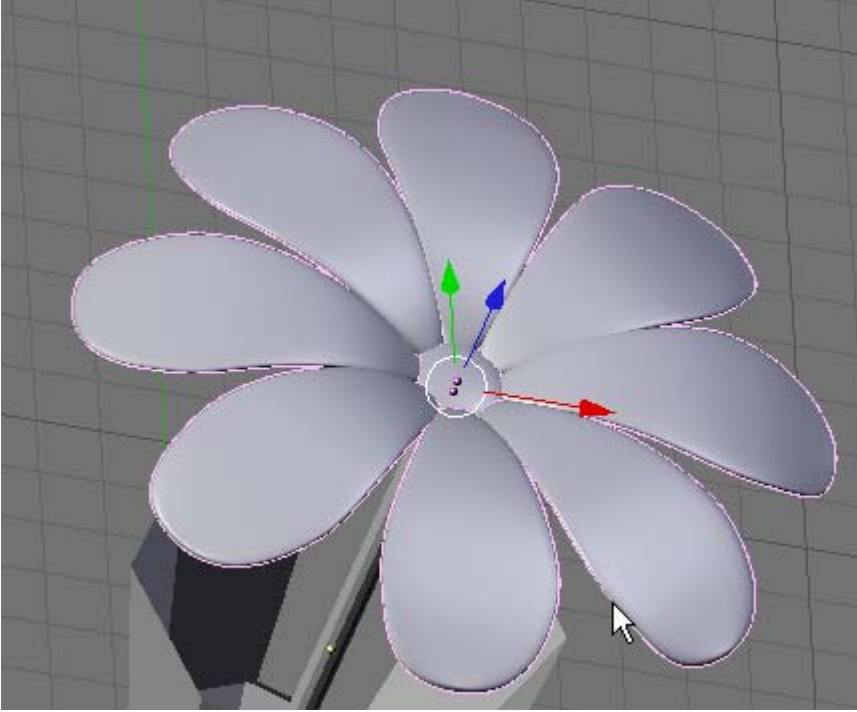

Switch back to Front View. With the Button and Petal objects selected press SHIFT-D (Duplicate). Move the duplicate Petals and Button to the Curved Stem object.

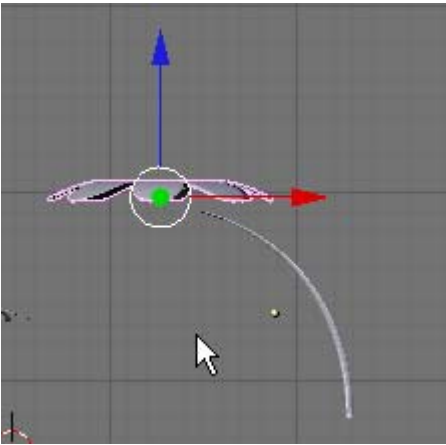

Zoom in a bit and press the RKEY (Rotate) and rotate the Button and Petal objects so they correspond with the Curved Stem.

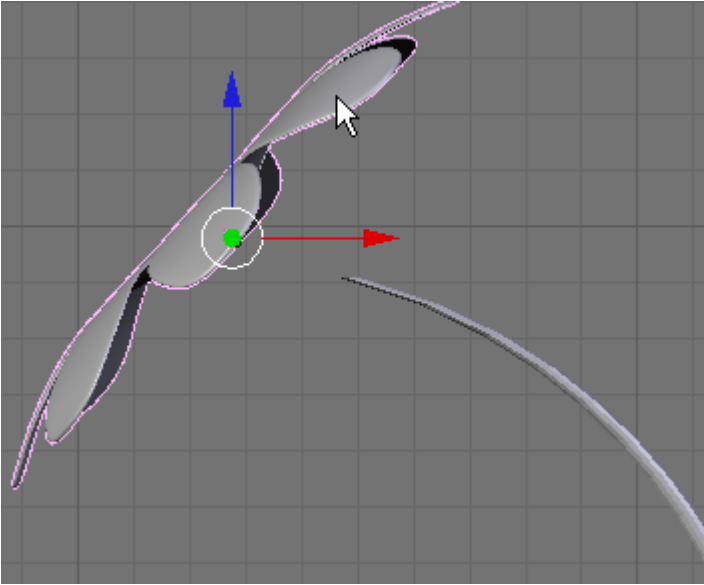

Press the GKEY and position the Petals and Button to the Curved Stem. Rotate your Front View to make sure the Stem does not stick out of the Button. Adjust the Petals and Button as needed.

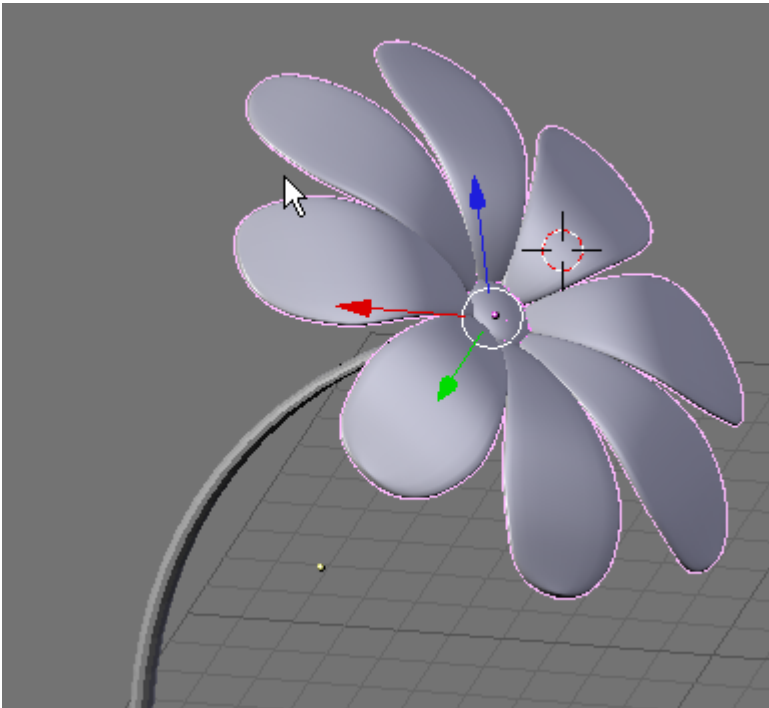

Select the Petals, Button and Curved Stem. Switch back to Front View. Press the ZKEY (Wireframe Mode). Press the GKEY (Grab) and place the flower into the Vase.

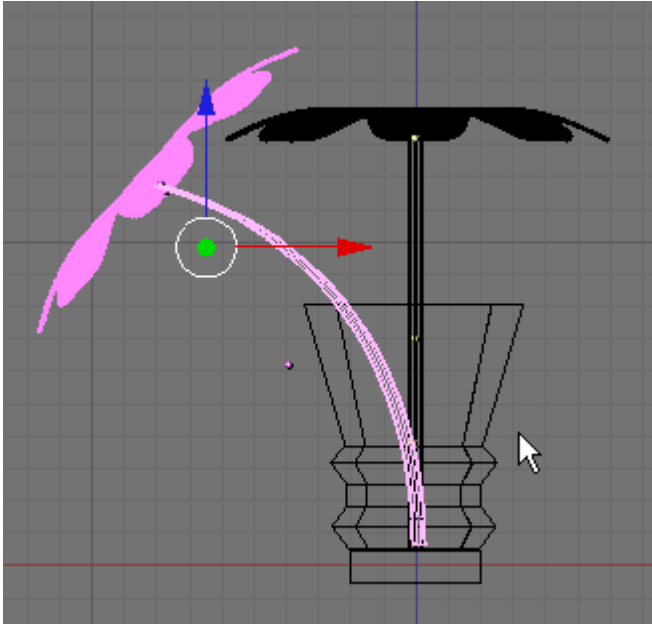

Switch to Top View and place your 3D cursor in the center of the Vase.

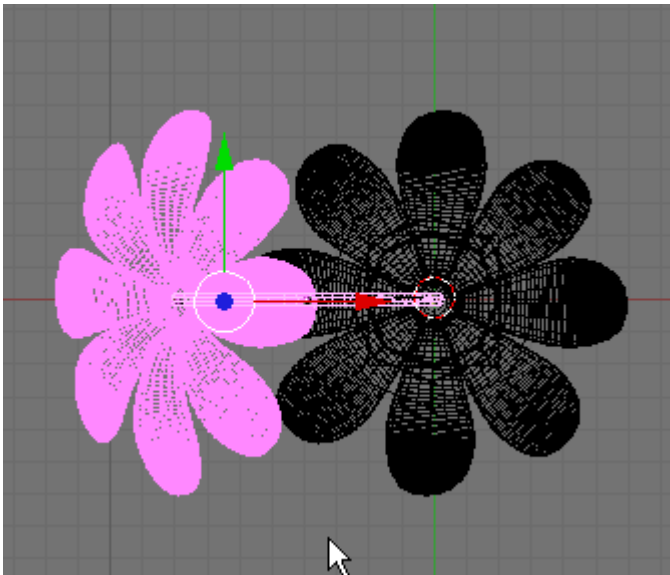

Change the Rotation/Scaling Pivot Point to 3D Cursor.

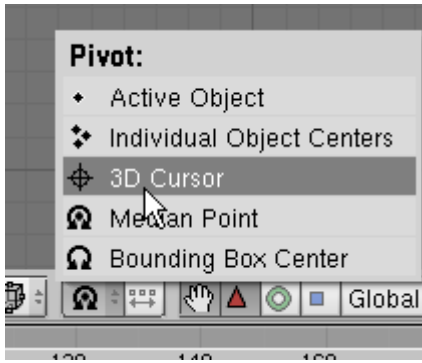

With the Curved Stem, Duplicate Petal and Button still selected Press SHIFT-D (Duplicate). Press the RKEY (Rotation) and rotate the duplicate flower as shown below.

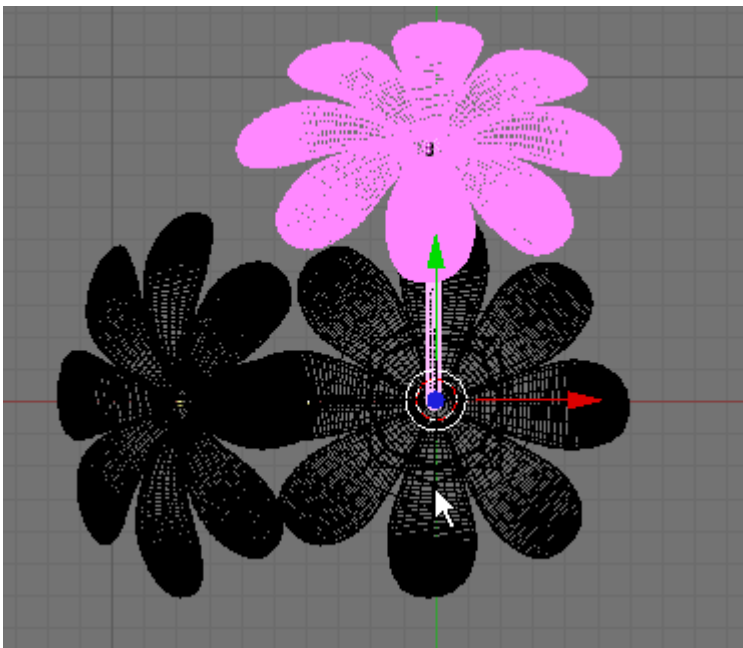

Duplicate and rotate 2 more times to create 2 more flowers and position them as shown below.

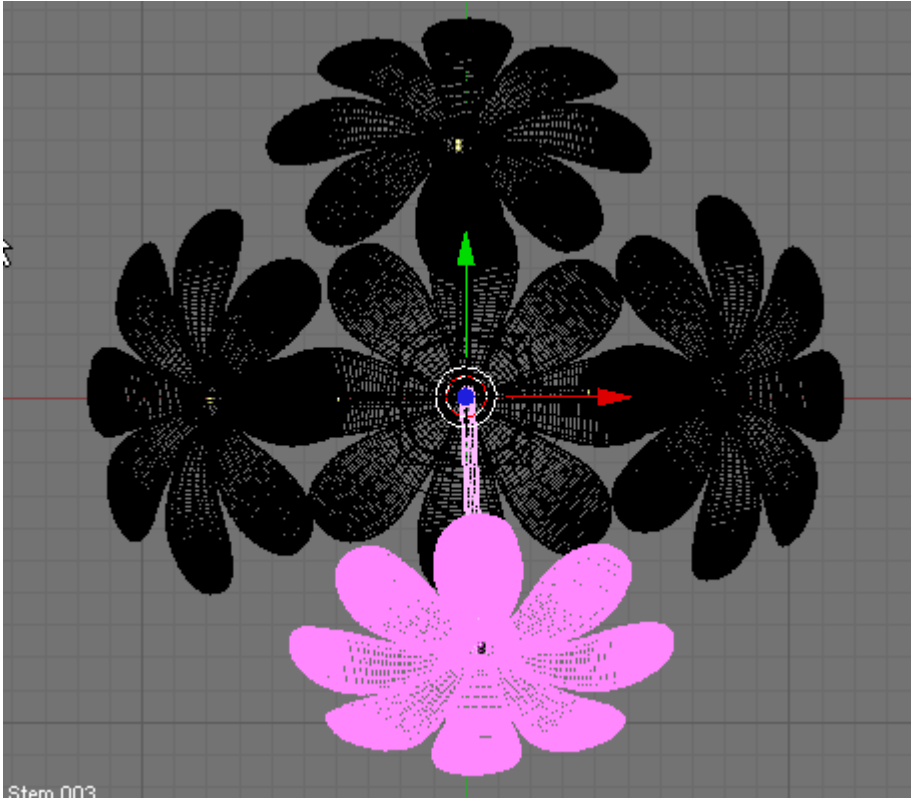

Switch to Front View. Select all of the Stems (5 in total).

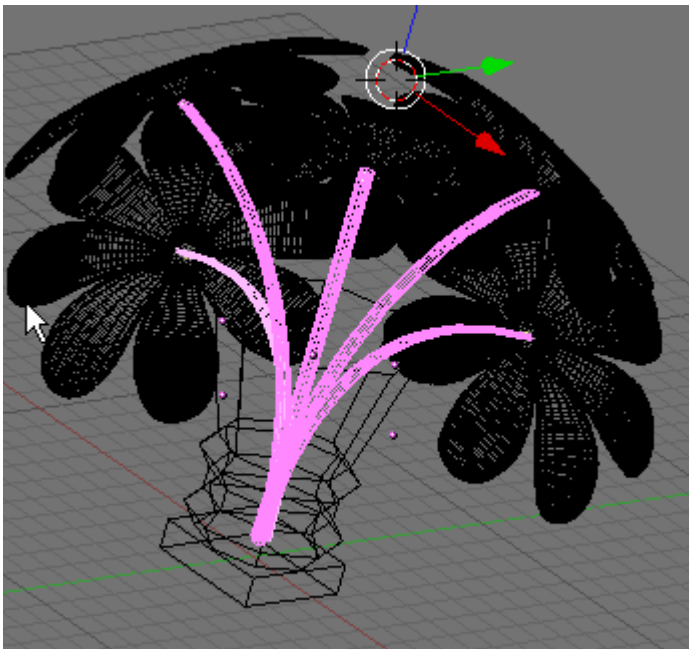

In the Link and Materials Panel press the Set Smooth button.

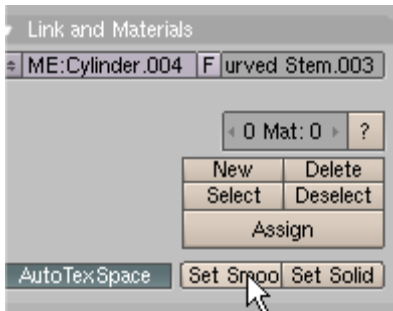

Change the Rotation/Scaling Pivot Point to back to Median Point.

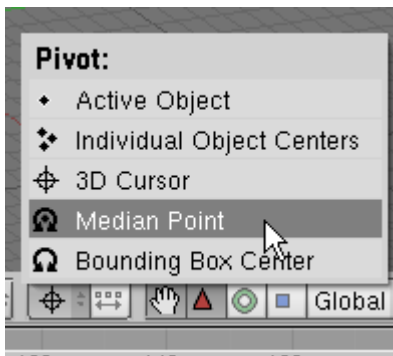

Select the Vase object. Press the MKEY (Layer) and place the Vase object on Layer 1.



Now select all of the flowers. Press the MKEY (Layer) and place the flowers on Layer 2

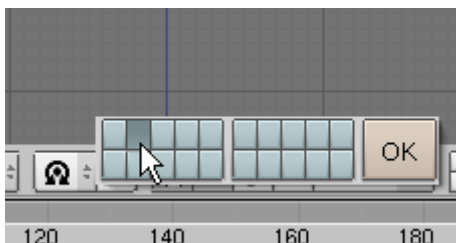

Turn on Layer 2 only. Select all of the Petals objects from all of the flowers. Press the MKEY and place all of the Petal objects on Layer 4.



Select all of the Stem objects. Press the MKEY and place all of the Stem objects on Layer 3

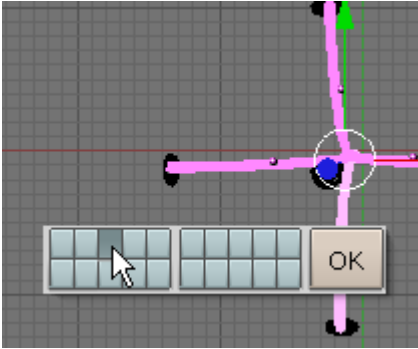

To recap, we have:
Layer 1 – Vase
Layer 2 – Buttons
Layer 3 – Stems
Layer 4 – Petals

Turn on Layers 1, 2, 3 and 4.

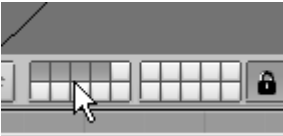

Save your file CTRL-W.

We will now add a floor and corner walls to the scene. Switch to top view. Press the AKEY to deselect the objects. Zoom out a bit and place your 3D cursor in the center of the vase.

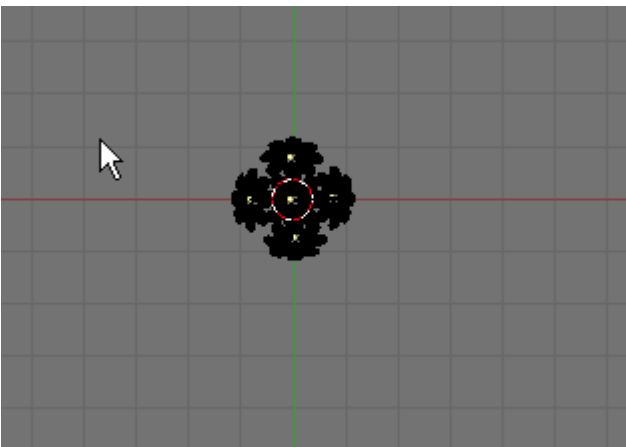

Press Space / Add / Mesh / Plane. Press the SKEY and scale the Plane object out as shown below (You may have to scale a number of times).

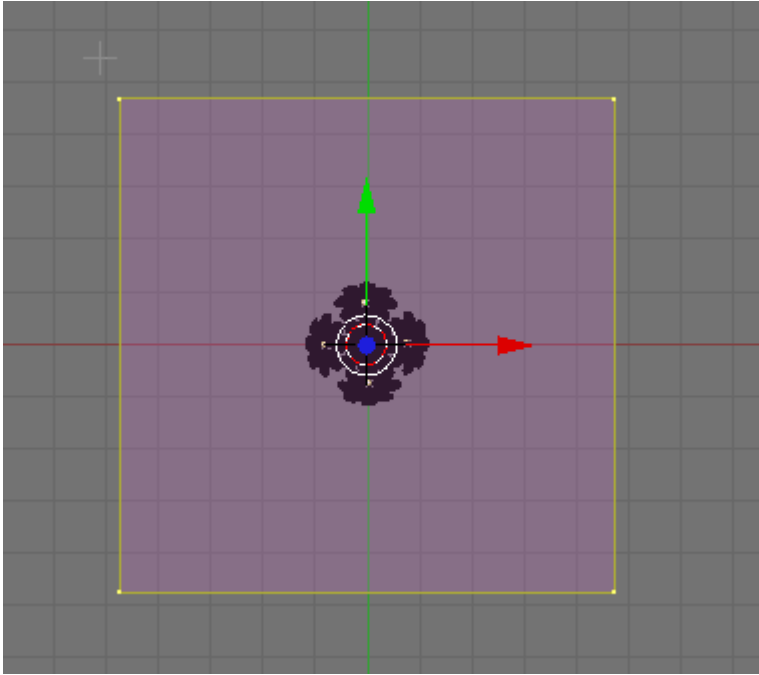

TAB out of Edit Mode. Press the RKEY (Rotate) and rotate the Plane object as shown below.

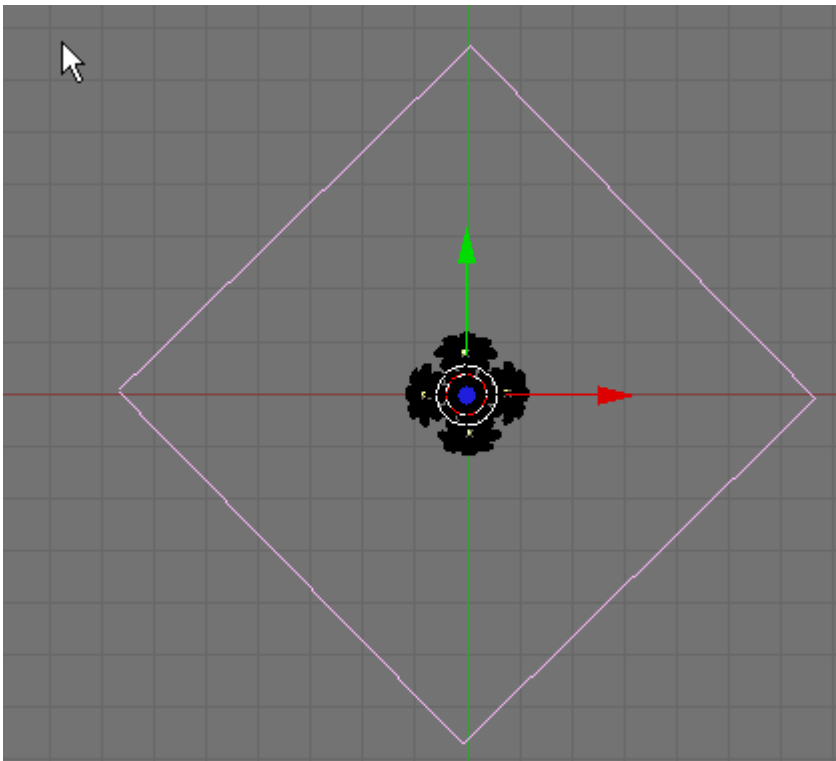

Switch to Front View. Use the Blue Transform Widget Arrow to Move the Plane so that the Vase is resting on it. (It should be very close already).

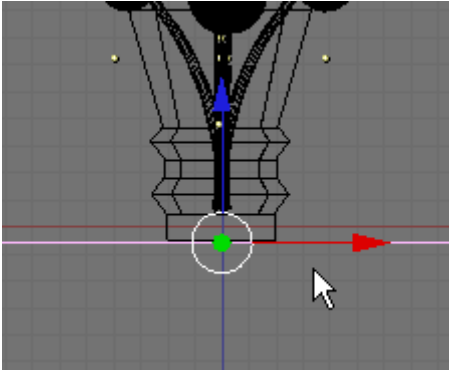

In the Transform Properties Panel name this object Floor.

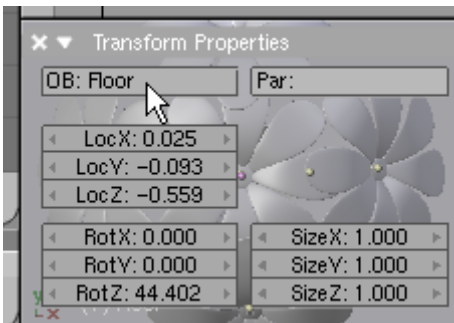

Switch to top View and Zoom out a bit. Place your 3D cursor near the top left edge of the Floor.

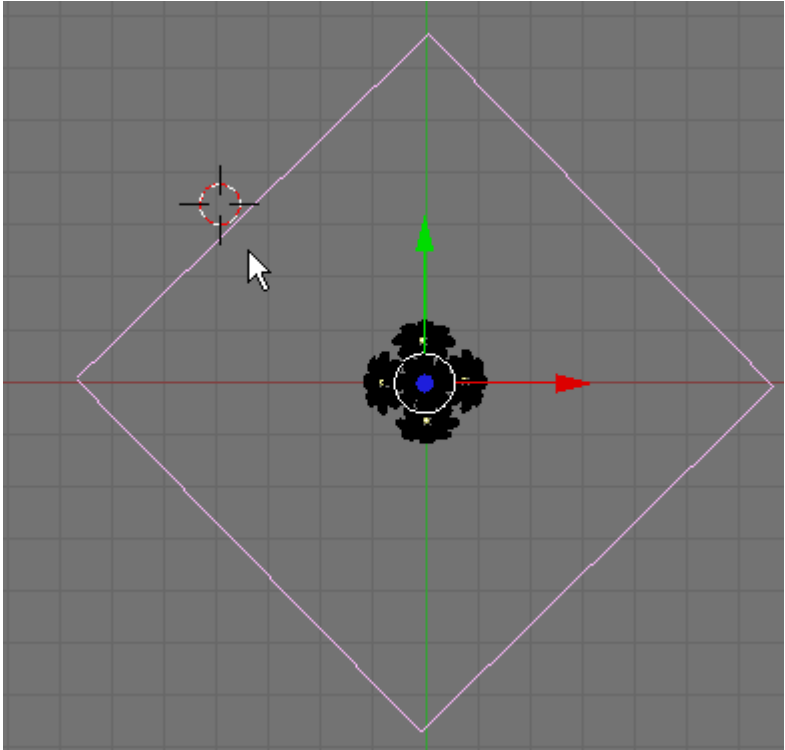

Press Space / Add / Mesh / Cube. TAB out of Edit Mode. In the Transform Properties Panel name this object Left Wall. Set the Size X: to 50. Size Y: to .2 and Size Z to 18.



Press the RKEY and rotate the Left Wall object to the angle of the Floor.

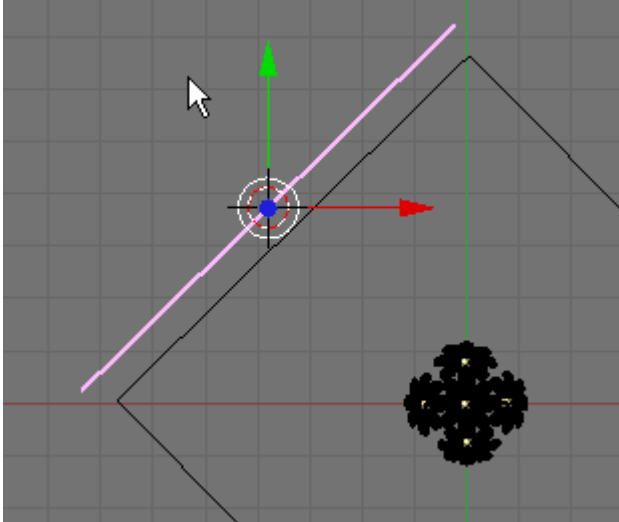

Press the GKEY and Move the Left Wall to the Edge of the Floor.

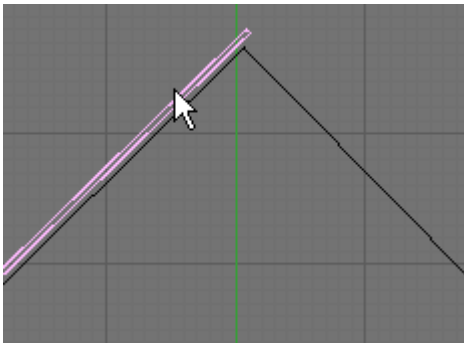

Switch to Front view. Use the Blue Transform Widget Arrow to move the Left Wall object up to the floor level.

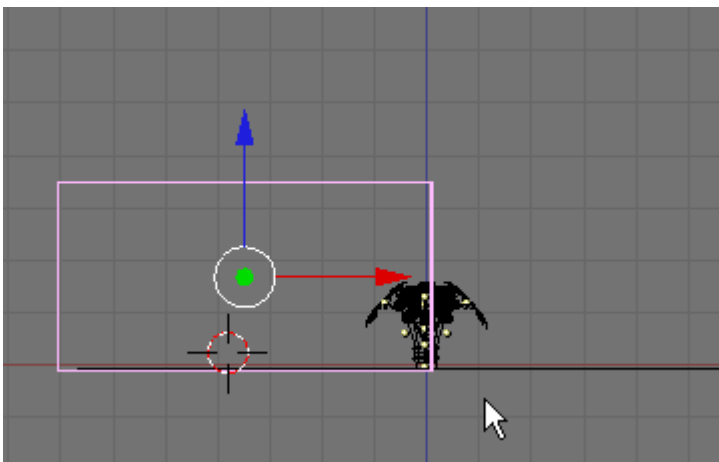

Switch to Top View. Press SHIFT-D (Duplicate). Move and rotate this duplicate wall into position on the right side of the floor forming a corner behind the vase.

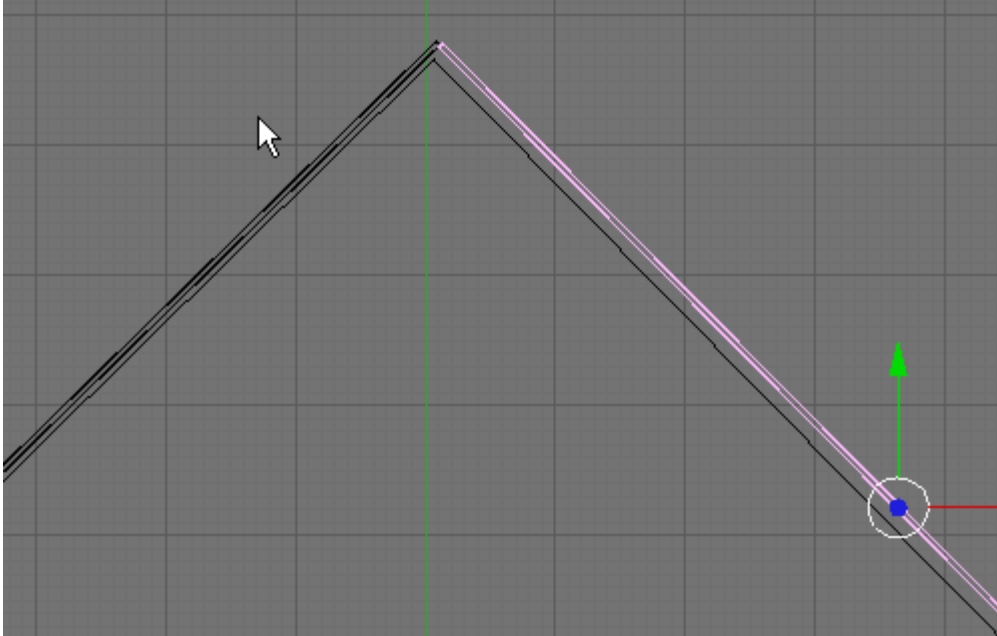

In the Transform Properties Panel name this object Right Wall.



Select the Floor, Left Wall and Right Wall objects. Press the MKEY (Layer) and place these objects on layer 5.



Save your file CTRL-W.

Turn on Layers 2, 3, and 4 only. Select all of the flowers (Buttons, Stems and Petals). Add Layer 1 to the scene. Use the Blue Transform Arrow to raise the flowers up in the vase as shown.

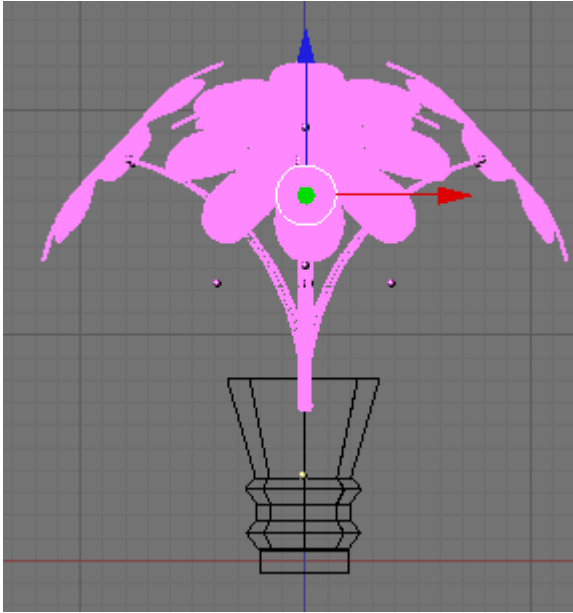

Add Layer 4 to the Scene.

Add Layer 10 to the scene. This layer contains the Camera Main and Camera Focus objects. Select the Camera Focus object from the Outliner Window.



Press the GKEY and move the Camera focus to the center of the Vase/ Flower arrangement.

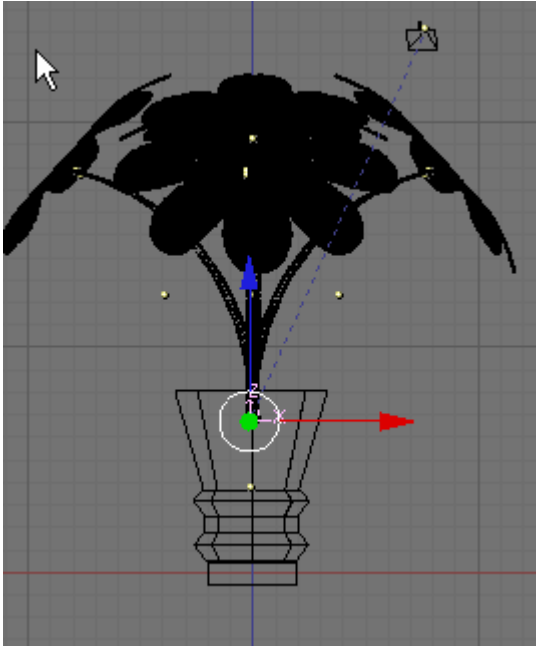

Click in the Perspective Viewport and change it to Camera (NUM0).

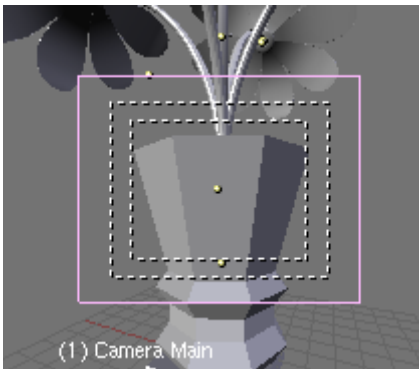

Select the Camera object. Use the top, front and side viewports to position the camera so that the camera viewport looks something like shown below.

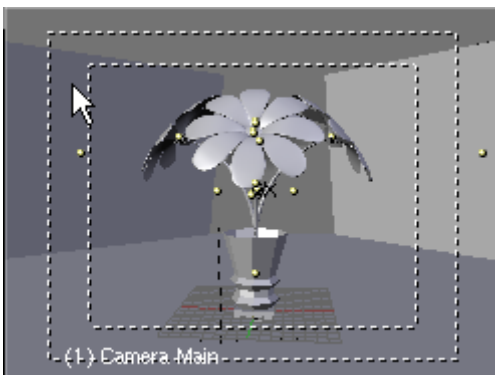

Note that in my camera view the Walls behind the flowers seem as if they are apart. (You may have something like this on yours. The problem is that by default Blender's camera is "clipped" at 100 units. Anything beyond 100 units will not appear in the camera view. Press F9 (Editing) if not already displayed. In the Camera Panel increase the ClipEnd setting until the walls appear closed. (My setting is 120)

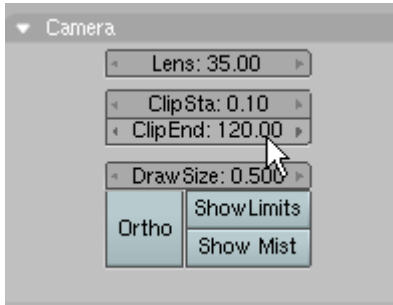

The walls should now appear closed in camera view.

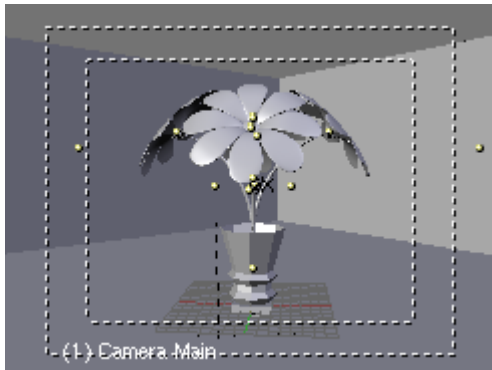

Notice that in the camera view we can see the top edge of the Left and Right Walls. We want a solid corner background so we need to increase the height of the two walls. Select the Left Wall object. In the Transform Properties Panel increase the Size Z: setting until the wall is high enough to fill the background of the camera view (My setting is 30).

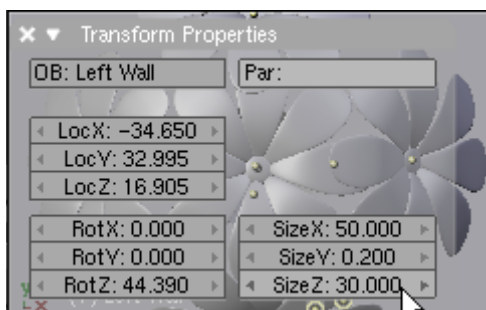

Select the Right Wall object and do the same.



The walls now fill the camera view.

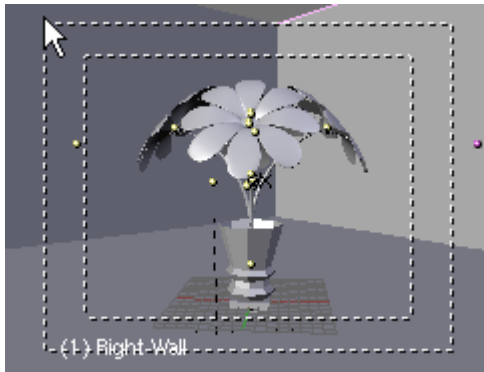

Save your file CTRL-W.

We will now apply some simple colors to the objects. Switch to Front View. Turn on Layer 5 only (Floor and Walls). Select the Floor Object. Press F5 (Shading). Click the Add New Button. Name the Material Floor Green and adjust the color Sliders to:

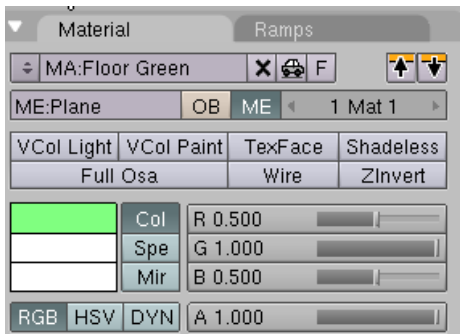

Select the Left Wall Object. Click the Add New Button. Name the Material Wall Yellow and adjust the color Sliders to:

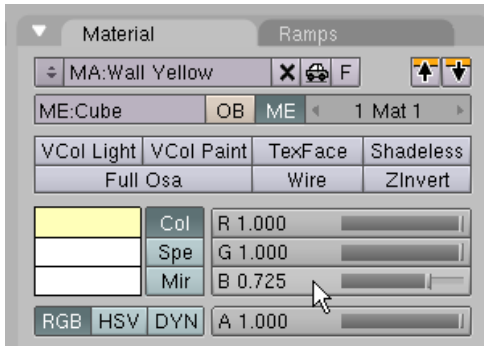

Select the Right Wall Object. Click the small arrow to the left of the Add New Button. Add the Wall Yellow Material to it.



Turn off Layer 5 and turn on Layer 1. Select the Vase. Click the Add New Button. Name the Material Vase Purple and adjust the color Sliders to:

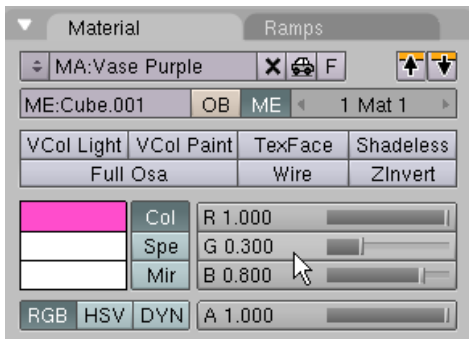

Turn off Layer 1 and turn on Layer 2. Select one of the Button objects. Click the Add New Button. Name the Material Button Yellow and adjust the color Sliders to:

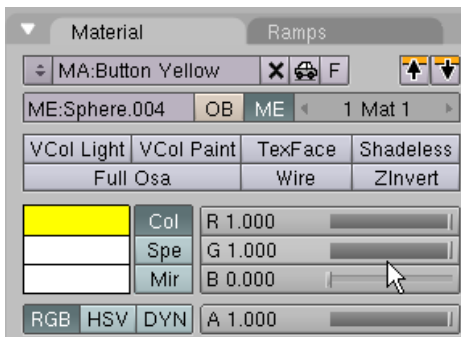

Select a different Button object. Click the small arrow to the left of the Add New Button. Add the Button Yellow Material to it.

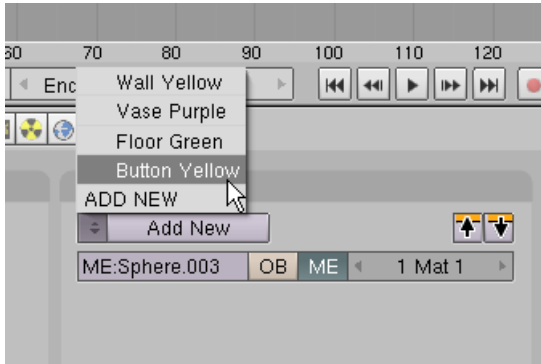

Add the Button Yellow Material to the other buttons as well in the same manner.

Turn off layer 2 and turn on layer 3. Select one of the Stem objects. Click the Add New Button. Name the Material Stem Green and adjust the color Sliders to:

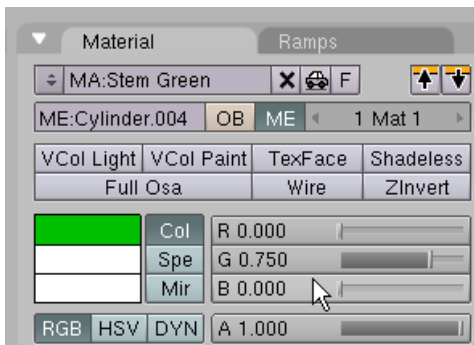

Add the Stem Green Material to the other Stem objects.

Turn off layer 3 and turn on layer 4. Select one of the Petals objects. Click the Add New Button. Name the Material Petal White and adjust the color Sliders to:

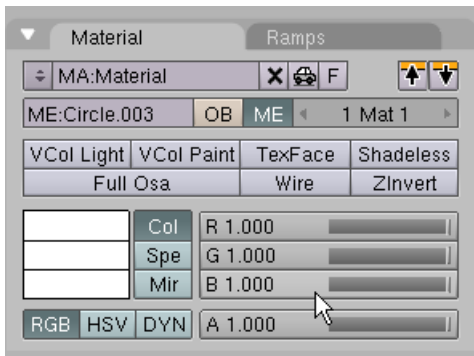

Add the Petal White Material to the other Petals objects.

Turn off layer 4 and turn on Layer 20. This layer contains the lighting set-up. Since we are using a floor and a back wall we do not need the Sun Back and Sun Bottom lamps. Select the Sun Back lamp from the Outliner Window and delete it. Select the Sun Bottom lamp from the Outliner Window and delete it.

Switch to Front View. Turn on Layers 1, 2, 3, 4, 5, 10, and 20.

Save your file CTRL-W.

Render the camera view F12.



The objects are rendered in the Material colors assigned. We want to use Blender's Toon rendering function for this scene. Press F10 (Scene). In the Output Panel press the Edge button.

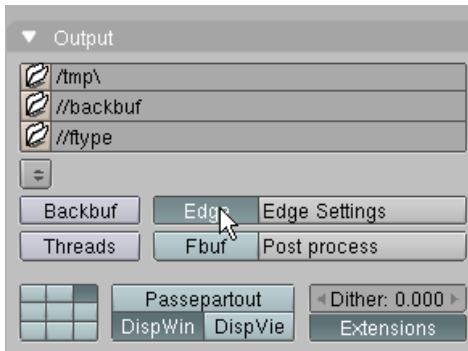

Press the Edge Settings button. Leave the Outline color the default black. Set the Enit (Edge Integer Thickness) setting to 255 and the AntiShift setting to 115.

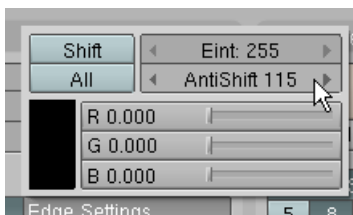

Render F12.



Here are some other images rendered from different camera positions.

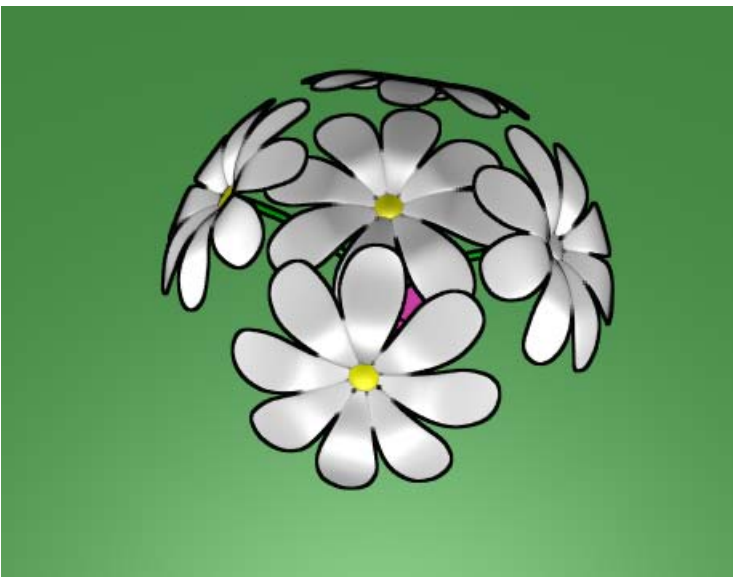



You can save your rendering as an image file by pressing F3. Select the directory you want the image saved and name the file (you must add the .jpg file extension). Press Save JPEG when finished.

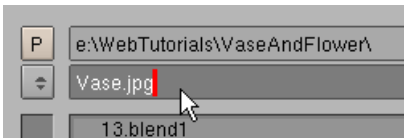

A finished copy of this tutorial file named VaseAndFlowerComplete.blend is located in the VaseAndFlower.zip file.